



Fashion STUDIES

Practical Manual
(CLASS-XII)



CENTRAL BOARD OF SECONDARY EDUCATION

Shiksha Kendra, 2, Community Centre, Preet Vihar, Delhi-110 301 India

नया आगाज़

आज समय की माँग पर
आगाज़ नया इक होगा
निरंतर योग्यता के निर्णय से
परिणाम आकलन होगा।

परिवर्तन नियम जीवन का
नियम अब नया बनेगा
अब परिणामों के भय से
नहीं बालक कोई डरेगा

निरंतर योग्यता के निर्णय से
परिणाम आकलन होगा।

बदले शिक्षा का स्वरूप
नई खिले आशा की धूप
अब किसी कोमल-से मन पर
कोई बोझ न होगा

निरंतर योग्यता के निर्णय से
परिणाम आकलन होगा।

नई राह पर चलकर मंज़िल को हमें पाना है
इस नए प्रयास को हमने सफल बनाना है
बेहतर शिक्षा से बदले देश, ऐसे इसे अपनाए
शिक्षक, शिक्षा और शिक्षित
बस आगे बढ़ते जाएँ
बस आगे बढ़ते जाएँ
बस आगे बढ़ते जाएँ.....





Fashion Studies



Practical Manual

CLASS

XII



CENTRAL BOARD OF SECONDARY EDUCATION

Shiksha Kendra, 2, Community Centre, Preet Vihar, Delhi-110 301 India





Practical on Textile Science Class XI

PRICE: ₹

First Edition 2014, CBSE, India

Copies:

**"This book or part thereof may not be reproduced by
any person or agency in any manner."**

Published By : The Secretary, Central Board of Secondary Education,
Shiksha Kendra, 2, Community Centre, Preet Vihar,
Delhi-110301

Design, Layout : Multi Graphics, 8A/101, W.E.A. Karol Bagh, New Delhi-110005
Phone: 011-25783846

Printed By :



भारत का संविधान

उद्देशिका

हम, भारत के लोग, भारत को एक सम्पूर्ण ¹[प्रभुत्व-संपन्न समाजवादी पंथनिरपेक्ष लोकतंत्रात्मक गणराज्य] बनाने के लिए, तथा उसके समस्त नागरिकों को:

सामाजिक, आर्थिक और राजनैतिक न्याय,
विचार, अभिव्यक्ति, विश्वास, धर्म
और उपासना की स्वतंत्रता,
प्रतिष्ठा और अवसर की समता

प्राप्त कराने के लिए

तथा उन सब में व्यक्ति की गरिमा

और ¹[राष्ट्र की एकता और अखंडता]

सुनिश्चित करने वाली बंधुता बढ़ाने के लिए

दृढ़संकल्प होकर अपनी इस संविधान सभा में आज तारीख 26 नवम्बर, 1949 ई० को एतद् द्वारा इस संविधान को अंगीकृत, अधिनियमित और आत्मार्पित करते हैं।

1. संविधान (बयालीसवां संशोधन) अधिनियम, 1976 की धारा 2 द्वारा (3.1.1977) से “प्रभुत्व-संपन्न लोकतंत्रात्मक गणराज्य” के स्थान पर प्रतिस्थापित।
2. संविधान (बयालीसवां संशोधन) अधिनियम, 1976 की धारा 2 द्वारा (3.1.1977) से “राष्ट्र की एकता” के स्थान पर प्रतिस्थापित।

भाग 4 क

मूल कर्तव्य

51 क. मूल कर्तव्य - भारत के प्रत्येक नागरिक का यह कर्तव्य होगा कि वह -

- (क) संविधान का पालन करे और उसके आदर्शों, संस्थाओं, राष्ट्रध्वज और राष्ट्रगान का आदर करे;
- (ख) स्वतंत्रता के लिए हमारे राष्ट्रीय आंदोलन को प्रेरित करने वाले उच्च आदर्शों को हृदय में संजोए रखे और उनका पालन करे;
- (ग) भारत की प्रभुता, एकता और अखंडता की रक्षा करे और उसे अक्षुण्ण रखे;
- (घ) देश की रक्षा करे और आह्वान किए जाने पर राष्ट्र की सेवा करे;
- (ङ) भारत के सभी लोगों में समरसता और समान भ्रातृत्व की भावना का निर्माण करे जो धर्म, भाषा और प्रदेश या वर्ग पर आधारित सभी भेदभाव से परे हों, ऐसी प्रथाओं का त्याग करे जो स्त्रियों के सम्मान के विरुद्ध हैं;
- (च) हमारी सामासिक संस्कृति की गौरवशाली परंपरा का महत्त्व समझे और उसका परिरक्षण करे;
- (छ) प्राकृतिक पर्यावरण की जिसके अंतर्गत वन, झील, नदी, और वन्य जीव हैं, रक्षा करे और उसका संवर्धन करे तथा प्राणिमात्र के प्रति दयाभाव रखे;
- (ज) वैज्ञानिक दृष्टिकोण, मानववाद और ज्ञानार्जन तथा सुधार की भावना का विकास करे;
- (झ) सार्वजनिक संपत्ति को सुरक्षित रखे और हिंसा से दूर रहे;
- (ञ) व्यक्तिगत और सामूहिक गतिविधियों के सभी क्षेत्रों में उत्कर्ष की ओर बढ़ने का सतत प्रयास करे जिससे राष्ट्र निरंतर बढ़ते हुए प्रयत्न और उपलब्धि की नई उंचाइयों को छू ले;
- ¹(ट) यदि माता-पिता या संरक्षक है, छह वर्ष से चौदह वर्ष तक की आयु वाले अपने, यथास्थिति, बालक या प्रतिपाल्य के लिये शिक्षा के अवसर प्रदान करे।

1. संविधान (छयासीवां संशोधन) अधिनियम, 2002 की धारा 4 द्वारा (12.12.2002) से अंतः स्थापित।

THE CONSTITUTION OF INDIA

PREAMBLE

WE, THE PEOPLE OF INDIA, having solemnly resolved to constitute India into a ¹**[SOVEREIGN SOCIALIST SECULAR DEMOCRATIC REPUBLIC]** and to secure to all its citizens :

JUSTICE, social, economic and political;

LIBERTY of thought, expression, belief, faith and worship;

EQUALITY of status and of opportunity; and to promote among them all

FRATERNITY assuring the dignity of the individual and the² [unity and integrity of the Nation];

IN OUR CONSTITUENT ASSEMBLY this twenty-sixth day of November, 1949, do **HEREBY ADOPT, ENACT AND GIVE TO OURSELVES THIS CONSTITUTION.**

1. Subs, by the Constitution (Forty-Second Amendment) Act. 1976, sec. 2, for "Sovereign Democratic Republic" (w.e.f. 3.1.1977)
2. Subs, by the Constitution (Forty-Second Amendment) Act. 1976, sec. 2, for "unity of the Nation" (w.e.f. 3.1.1977)

THE CONSTITUTION OF INDIA

Chapter IV A

FUNDAMENTAL DUTIES

ARTICLE 51A

Fundamental Duties - It shall be the duty of every citizen of India-

- (a) to abide by the Constitution and respect its ideals and institutions, the National Flag and the National Anthem;
- (b) to cherish and follow the noble ideals which inspired our national struggle for freedom;
- (c) to uphold and protect the sovereignty, unity and integrity of India;
- (d) to defend the country and render national service when called upon to do so;
- (e) to promote harmony and the spirit of common brotherhood amongst all the people of India transcending religious, linguistic and regional or sectional diversities; to renounce practices derogatory to the dignity of women;
- (f) to value and preserve the rich heritage of our composite culture;
- (g) to protect and improve the natural environment including forests, lakes, rivers, wild life and to have compassion for living creatures;
- (h) to develop the scientific temper, humanism and the spirit of inquiry and reform;
- (i) to safeguard public property and to abjure violence;
- (j) to strive towards excellence in all spheres of individual and collective activity so that the nation constantly rises to higher levels of endeavour and achievement;
- ¹(k) who is a parent or guardian to provide opportunities for education to his/her child or, as the case may be, ward between age of six and fourteen years.

1. Ins. by the constitution (Eighty - Sixth Amendment) Act, 2002 S.4 (w.e.f. 12.12.2002)



Foreword

The Central Board of Secondary Education introduced the subject of Fashion Studies as an independent elective subject at senior school level from the academic session 2004-2005. It has published the learning resource books for classes XI and XII with the active support and help of the National Institute of Fashion Technology, New Delhi. The present publication is a Manual for the Practical Work in Fashion Studies for class XII and it covers the practical component that has 30% weightage in the Board's Examination.

The manual gives simple practical tasks/projects in Pattern Making and Basics of Garment Making. Fashion Studies is basically a concept and skill-based subject requiring the students to plan, visualize and execute a number of designs to produce garments. Hence the practical component is of great importance in this subject. Moreover, students should also be taught to use different tools and equipments that are an integral part of design and garment making.

An attempt has been made to include basic exercises in exploration of patterns and simple garment making. They are aimed at helping the learners acquire the right perception and the elementary skill needed to establish a foothold in the field of fashion design and fashion technology. Meticulous care has been bestowed by the authors on the details of each exercise, providing adequate information by way of introduction, aim materials and methods, conclusions and references. The manual also includes essential information such as Tool Kit, Standard Dress Form Measurement Chart, Established Procedures for Test Fitting and Sewing Kit. A list of basic material and equipment needed for the practical work besides a set of safety rules in the Laboratory have also been included. It is expected that each candidate will perform all the 16 exercises given in the manual in class XII and maintain a portfolio for assessment following the procedure outlined in the manual. The viva questions given at the end of some exercises will help the learners develop an insight into the concepts and processes involved.

The eminent faculty of the National Institute of Fashion Technology, New Delhi have contributed to the development of this material. I express my sincere thanks to Mr. Prem Kumar Gera, Director General, NIFT, Sr. Prof. Bani Jha, Dean (Academic) and the NIFT faculty. Dr. Sadhana Parashar, Professor & Director (ART & I) and Dr. Kshipra Verma, Education Officer also deserve a special mention for planning and giving shape to this publication. Suggestions for further improvement of the publication will be most welcome.

Vineet Joshi
Chairman





Preface

Fashion theory and practices are built on an academic foundation where history, anthropology, sociology, psychology and economics intermingle to shed light on clothing as one of the three most essential needs of the human race. It is a visual indicator of the cultural identity of a country.

Fashion is a dynamic force which influences lifestyle choices made by consumers. It drives international trends in a multitude of areas from apparel, accessories, automobiles, cuisine, wellness, vacations and more. Glamour notwithstanding, fashion is a serious global business with high financial stakes. The increasing references to Indian textiles, clothing and culture on international fashion scenario are indicative of India being centre-stage on the global fashion map.

The current educational environment provides students with a wide range of subjects that are informative and also encourages individual aptitude. Many want to pursue non-traditional careers where creativity, problem-solving and business acumen integrate into an exciting combination. Fashion Studies introduced by CBSE at the 10+2 level as an elective academic subject, points in the direction of fashion as a creative and challenging career.

Fashion Studies offers insight into the components and processes of design, manufacturing, marketing in apparel and textiles. It encompasses the process from fibre to fabric, from concept to creation of garments. It provides an overview of fashion, an understanding of fabrics and surface techniques, design fundamentals and elements of garment-making.

Fashion Studies as a subject is envisaged to help students to make an informed decision about their future goals.

Sr. Prof Banhi Jha
Dean - Academic





Acknowledgements

CBSE

Mr. Vineet Joshi, IAS (Chairman)
Dr. Sadhna Parashar, Prof. & Director (ART & I)
Ms Kshipra Verma (Education Officer)
Dr Biswajit Saha (Associate Professor and Programme Officer)

HISTORY OF FASHION

Mr. Prem Kumar Gera, IAS
Sr. Prof Banhi Jha, Dean(Academic)

Anchor

Prof. Kripal Mathur

Contributors

1. Overview of Fashion : Sr. Prof. Banhi Jha
2. Introduction to Fibres, Dyeing and Printing : Dr. Nilanjana Bairagi
3. Design Fundamentals : Prof. Kripal Mathur
4. Elements of Garment making : Prof Vandana Narang & Ms Anu Jain





Contents

Total Marks 100

(Theory 70 + Practical 30)

Students will demonstrate their understanding of the subject through the following practical exercises:

Chapter 1: History of Fashion **01**

1. Ability to identify the cultural context of body adornment and its continuation in contemporary society
2. Ability to use visual references to analyze ancient draped garments
3. Ability to analyze the impact of Industrial Revolution during the British Raj in India
4. Ability to use books, museums, archives and movies as sources of information to explain the impact and influence of war on clothing

Chapter 2: Basic Pattern Making **05**

5. Be able to develop and test fit a basic bodice
6. Develop and test fit bodices through dart manipulation
7. Develop and test fit a basic skirt
8. Develop style variations of skirts

Chapter 3: Elements of Fashion **25**

9. Ability to design products with self-generated prints inspired from nature
10. To demonstrate creative exploration of patterns created by using food products for dyeing process
11. Ability to develop print designs inspired from animal skin by innovative use of materials
12. Ability to use the stencil printing technique to create design patterns

Chapter 4: Basics of Garment Making **29**

13. Stitch a sample of a continuous placket
 14. Stitch a sample of a basic shirt placket
 15. Stitch a sample of a basic shirt placket with facing
 16. Stitch a sample each of Extended facing, Bias facing and Shaped facing.
- 



Chapter 1

History of Fashion

PRACTICAL EXERCISE - 1

Objective

1. To enable students to identify examples of body adornment used in some societies
2. To understand the cultural context of such adornment
3. To visually trace the continuation of the same, with/without any modification or transformation, into contemporary society.

Material Requirement

1. Unlined/ blank sketchbook (A3)
2. Scissor, glue
3. Magazines (e.g. National Geographic, fashion magazines)

Procedure

1. Refer to books, magazines and the internet to find out about a primitive or tribal community from your country or any other.
2. Find pictures of different decorations and body adornment which typify the culture of this community. This may include clothes, accessories, scarification, tattooing, body painting, face painting etc.
3. Refer to magazines and identify pictures where there are noticeable similarities between the original body adornment and contemporary interpretations.
4. Cut these pictures and stick them in a notebook next to each other to highlight parallels.
5. Label the pictures with information regarding the community, country, period, regional name of the garment, accessory, technique, ritual (as applicable) etc.
6. Make a brief presentation for the class

Observation and Discussion

1. What are the typical visual cultural indicators of a community?
2. Have body decoration and adornment continued in their original form or have they undergone transformation in contemporary culture?





PRACTICAL EXERCISE - 2

Objective

1. To focus on the significance of draped garments in ancient Western and Asian civilizations as the precursor to cut and sewn garments
2. To enable students to understand the process of using visual references to analyze the drapery of ancient garments

Material Requirement

1. Reference books on draped costume
2. Muslin fabric for draping

Procedure

Prior to the exercise, the teacher may brief students on the following:

1. Specific civilizations (Indian or Western) where draped garments were extensively worn
2. Interpretation of reference materials to understand and analyze the details of draping

Each student will do the following:

1. Refer to books, magazines and the internet to identify pictures of draped garments according to the civilization
2. Make a step-by-step drawing of the process of draping the garment on sheets/notebook

Observation and Discussion

1. How has draped clothing evolved in India or in other countries?
2. Do museum sculptures or pictures help in replication of drapes?

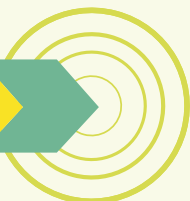



PRACTICAL EXERCISE - 3

Objective

1. To enable students to understand the impact of the Industrial Revolution during the British Raj in India

Material Requirement

1. Unlined/blank sketchbook (A3)
2. Scissor, glue

Procedure

1. Identify specific categories of textiles and clothing worn in England and Europe which were based on Indian exports during the Industrial Revolution
2. Refer to books, journals in the library and the internet to do the following:
 - i) Find and photocopy an article on the impact of restrictive rules on Indian weavers during the British Raj
 - ii) Identify pictures of European garments which used Indian textiles and prints
3. Visit a museum for additional information (optional)
4. Use photocopies of visuals and stick them in a notebook with suitable labels indicating the product (textiles and clothing), reference name (if any) and year.
3. Make a presentation to the class

Observation and Discussion

1. What were the short-term and long-term repercussions of Industrial Revolution in India?
2. Are the traditional textile prints and apparel designs still used by textile and fashion designers?

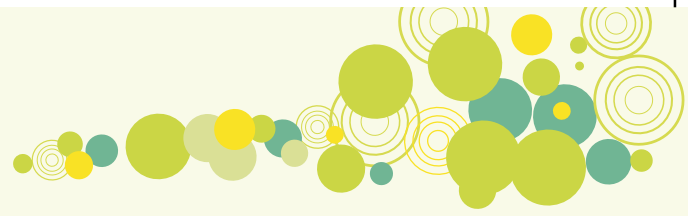

PRACTICAL EXERCISE - 4

Objectives

1. To focus on the impact and influence of war on clothing
2. To learn to use books, museums, archives and movies as sources of information on war and war clothing

Material requirement

1. Unlined/ blank sketchbook (A3)
2. Scissor, glue
3. Fashion magazines

Procedure

1. Refer to books, journals in the library and the internet with a focus on any war which occurred in the 20th century.
2. Find articles and photographs of uniforms worn by both the armies.
3. Analyze the uniforms and accessories in terms of material, silhouette, colour, details etc.
4. Photocopy these visuals and label them suitably with information related to the war and the year/duration.
5. Find visuals from contemporary magazines which show war uniform-inspired fashion and label them suitably with information on the designer, the show and the year.
6. Stick the visuals on sheets/ notebook

Observation and Discussion

1. Is the impact of war on clothing a historical phenomenon or does it still continue to find expression in modern clothing?
2. In what way would war uniform-inspired fashion be considered to be an example of zeit geist?

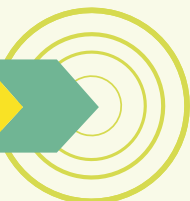



Chapter 2

Basic Pattern Development

Introduction

Pattern making is an extensive subject which covers principles of constructions and techniques in a wider sense rather than style detail in narrow sense. It opens up the scope for an infinite variety of styles both for regular designs and fantasy patterns. Pattern construction can be divided in two parts: measuring correctly & knowledge of technique with which they are applied. Learning pattern making by trial and error is like learning to play music by ear.

This is a method where in body or dress form measurements are taken for developing a pattern. Following a logical stepwise procedure, the measurements are then converted into a pattern. In other words this system depends on accurate measurements to complete the paper pattern. Limitless designs can be achieved for practical garments. Flat pattern making should be done in conjunction with a dress form so that as the design evolves, the proportion and balance of the garment can be checked side by side. It is important to transfer the pattern on to a muslin toile (pronounced as 'twall') to test the fit, on a dress form or a human figure. Flat pattern cutting is now widely used because of its accuracy of sizing and the speed with which complicated designs can be made.

Basic Preparation

Prior planning and clarity is necessary for the performance of the exercises.

Read handouts, appropriate lab manuals and textbooks before performing for the practical. Follow all precautions and regulations while working in the lab.

Listen carefully to any introductory remarks and experimental procedure given by your teacher.

Make sure that your working space is clean and organized, and all the required stocks and materials are kept ready.

Maintain the discipline in your working area.

Recording Results

Results should be recorded in the recommended record/file neatly and legibly with great care. The record of exercises may be done in the following headings:

1 Introduction/Aim

State precisely the purpose and objectives of the practical in two or three sentences.



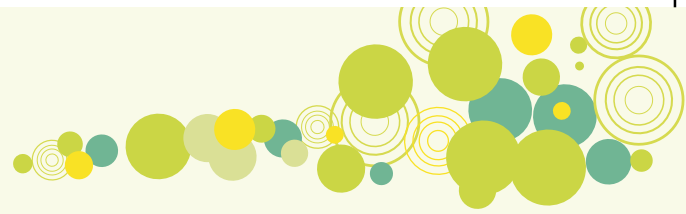

2. Materials and methods

The requirements like equipment, materials, etc. should be given here. Besides, methods should also be described along with principles of the techniques used.

3. Sample / Results

The paper pattern corrected after test fitting should be labeled, neatly folded, placed in a transparent envelope and attached here.

Things to be included on a pattern are:-

- ❁ Grain line
- ❁ Centre Front or Centre Back
- ❁ Style number or code number of the pattern set may be evolved e.g. AB 01 here AB identify type of the garment and 01 identify the piece number of complete set. If there are 5 pattern pieces in a garment, the pieces will be numbered as AB 01, AB 02, AB 03, AB 04 and AB 05.
- ❁ Pattern piece e.g. skirt front, skirt back, side front etc.
- ❁ Size as 32, 34, 36, or S, M, L etc.
- ❁ Cutting information - It should be clearly mentioned as to how many pieces are to be cut e.g. Cut 1, Cut 2, Cut on fold.
- ❁ Notches - Marks that are needed to help assemble garment sections correctly.
- ❁ Directional Fabrics - For fabrics which have designs in one direction such as floral print, stripes, plaid, velvet, fur etc. A symbol "cut one way" or (?) is indicated on the pattern.
- ❁ Date - Indicated as a reference point.
- ❁ Seam Allowances.

Seam Allowances

The amount of seam allowance required for each seam line may vary depending on the location and end purpose. Generally these are the measurements followed -

- ¼" for sharp curves
- ½" for neckline, armhole, waistline, style line.
- 1" for side seam, centre line, shoulder, plackets.
- 2" for straight hem line.

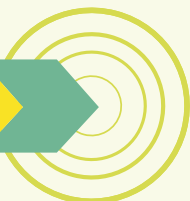

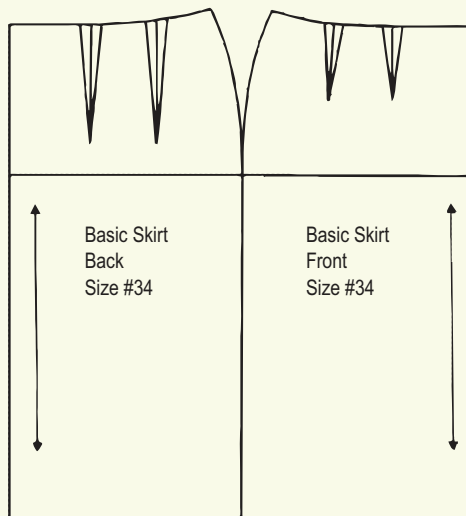
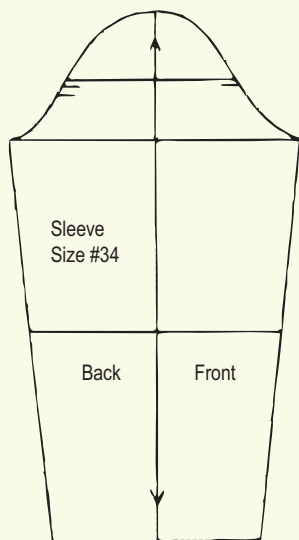
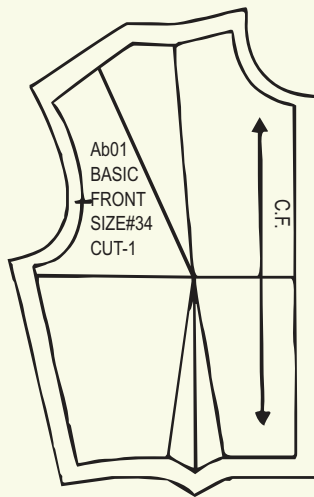
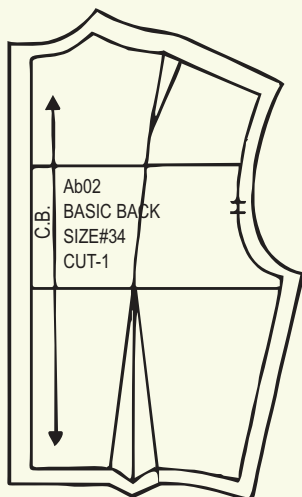

Symbols and abbreviations

Centre Front	-	CF
Centre Back	-	CB
Grain line	-	↕ ↔
Notches	-	⊥ □ < 4
Buttons	-	⊙
Button hole	-	—
Front	-	F
Back	-	B



FASHION STUDIES

Waist line	-	Wl
Arm hole	-	Ah
Side Seam	-	SS
Neck line	-	NI
Shoulder	-	Sh
Two way grain line	-	↕
One way grain line	-	↓ ↑

4. Discussion and Conclusions

The test fits should be interpreted and conclusions be drawn after discussing with your teacher.

5. References

Reading materials that were consulted for the experiment be given as reference (e.g. your lab manual) along with the name of the author and the book, pages referred and year of publication.

Safety rules in the laboratory

- ❁ Safety is important to everyone and it is ones responsibility to maintain a safe working place.
- ❁ When in doubt, ask the teacher.
- ❁ Report any injuries or accidents immediately to the teacher.
- ❁ Keep the work station clean with all tools in the tool kit.
- ❁ Turn off the iron at the end of the class.
- ❁ Always place the iron on the iron pad to avoid burning the ironing board cover.
- ❁ When trimming or cutting, put all trimmings & paper in the wastebasket.
- ❁ Scissors should be handed to another person with the handles toward the person.
- ❁ Never toss or throw scissors or equipment.
- ❁ Do not eat or drink in the work area.



PRACTICAL EXERCISE - 5

Objective

To develop a **basic bodice block** and test fit the same

Principles

A 'block' normally represents the dimensions of a specific form or figure. It has darts to fit to the contours of the body but no other design features. It is a foundation that is used to make the pattern for a design and has no seam allowances.

It is important that the correct block is chosen for the design; this not only saves time during adaptation but can affect the final shape. The basic blocks can be drafted to fit individual figures by using personal measurements instead of the standard measurements listed in the size chart.

Requirements

Pattern paper, muslin and tool kit

Procedure

- To develop pattern for basic Bodice for womens wear, use measurements from the given chart (ref Annexure II) or measure a dress form or a body. Cut a paper, whose length is front length plus 3" and width is half of the bust width plus 4" on fold.
- Fold the paper lengthwise and with fold on the left hand side mark a guideline 1" down from the top edge, mark A as illustrated.

A to B = front length

A to C = B to D = front width (+1/2"ease to be added if measured on dress form/body)

Join C to D

Mark D to E = centre front length

CE is front neck depth.

For neck width mark CF = CE - 1/8"

Square out lines from these points.

Draw the neckline curve as illustrated, using a French curve.

G = mid point of DE

GH = apex measurement

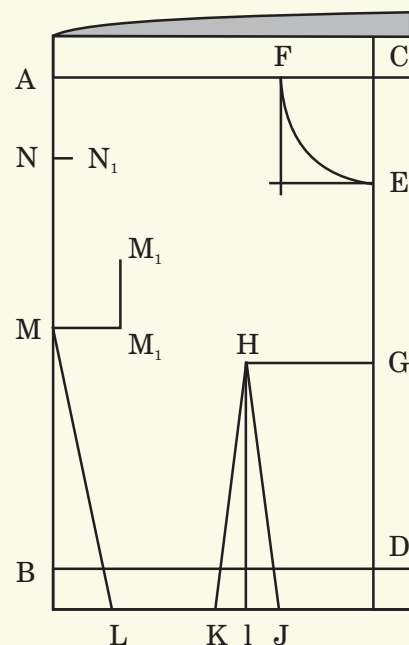

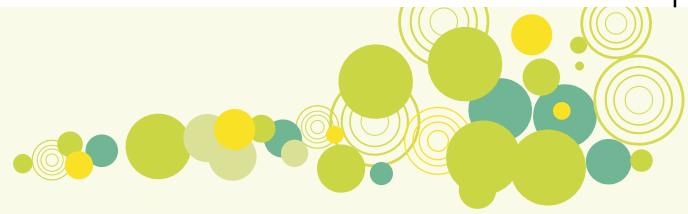

Square a line from H to I

- Mark DJ = Centre front to princess line measurement
- I K = I J, Join J and K to H
- KL = Front waist line measurement minus DJ (+1/8"ease to be added if measured on dress form/body)
- LM = under arm seam length. Join as illustrated
- M to M1 = M1 to M2 = 2 1/2" square out, as illustrated
- B to N = Shoulder to waistline measurement (+3/4"ease to be added if measured on dress form/body)
- N to N1 = 1/2"

Draw the front armhole curve as illustrated

Join F to N1

Mark F to F1 and N1 to O = 1/2 shoulder measurement

Join F1 to H and O to H.

Trace BD line, L M line and M M1 line on the other half of the paper.

Extend M M1 line on the second half of the paper.

Mark B to Z = Back width (+1/2"ease to be added if measured on dress form/body)

Z to Y = Centre Back Length

Y to X = CF

X to W = 7/8", draw the back neck line curve as illustrated.

Measure Z to L1 and from this subtract back waistline measurement (+1/8"ease to be added if measured on dress form/body).

The difference should be taken as dart intake at U.

Z to U = Centre back to princess line measurement.

Mark U to V = Dart intake, T is mid point of U and V

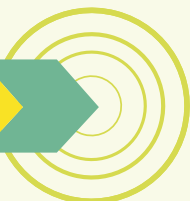
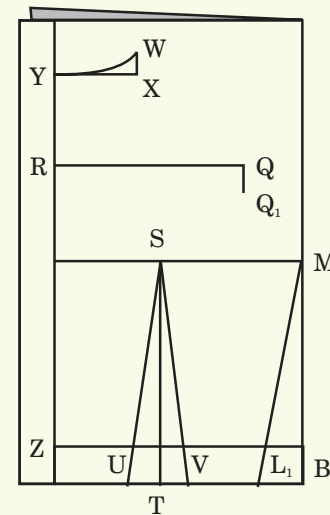
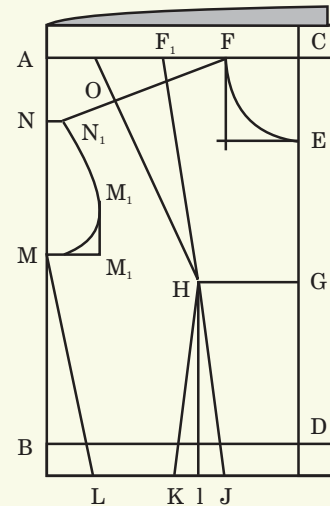



Square out from T to S, Join S to U and V.

Mark YR = $\frac{1}{4}$ Centre back length

R Q = Back shoulder blade measurement.

QQ1 = Draw 1" guideline, as illustrated.

Join W to N1 in front

W to P = $\frac{1}{2}$ shoulder + $\frac{1}{8}$ "

P to P1 = $\frac{3}{4}$ "

P1 to P2 = W to P ($\frac{1}{2}$ shoulder + $\frac{1}{8}$ "

Join P to S.

Join P1 to P3 such that P3 is 1" above the shoulder/blade line (RQ).

Draw the armhole as illustrated.

Truing or correcting the lines or darts to conform to body shape or aligning the dart legs and seams.

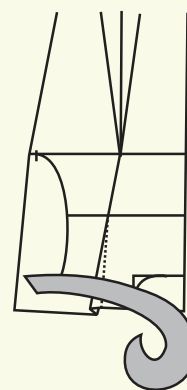
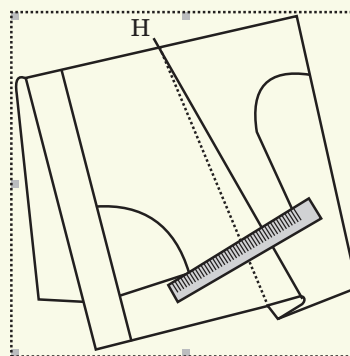
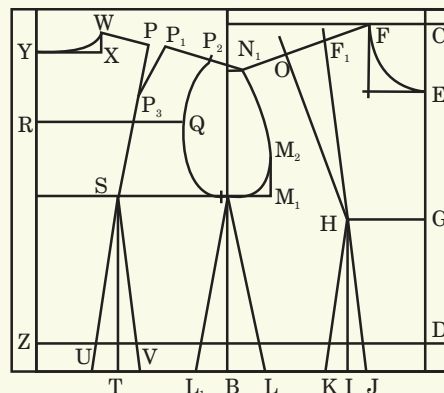

Front shoulder

Fold the shoulder dart at the apex, matching the two dart legs keeping the folded edge towards the neckline. Join the neck edge with the armhole edge with the straight line at the dart ends. Use a tracing wheel to trace out the folded edge.

Back shoulder

Fold the shoulder dart matching the two dart legs keeping the folded edge towards the neckline. Draw the shoulder line with the help of the French curve as illustrated, dropping $\frac{1}{8}$ " on the armhole edge.

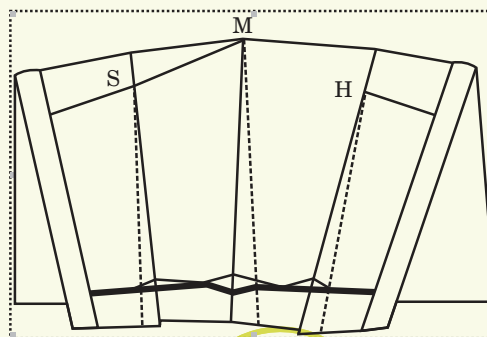



Waist line

Fold both the waist line darts (by matching the dart legs) and also close the side seam, keeping the pattern folded at the apex line.

True the waist with help of a French curve, blending the waist line darts and side seam. The side seam should be dropped $\frac{1}{4}$ " at the side

Observations

1. You are required to test fit the developed Bodice block and check the fit on muslin.
2. Make necessary changes if any and make the final pattern.

Viva questions

1. What are the important measurements for development of bodice block?
2. How do you ensure that the bodice is fitting well?

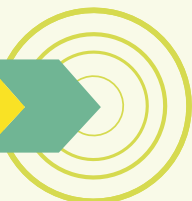
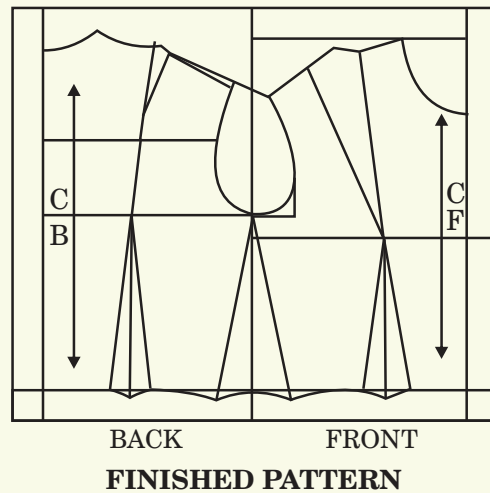

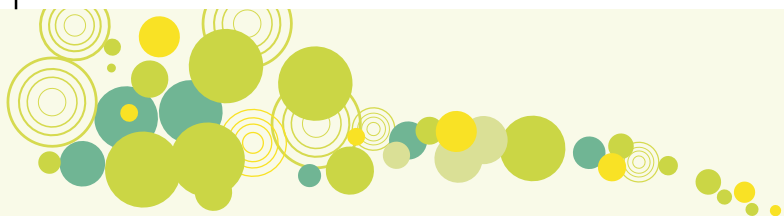

PRACTICAL EXERCISE - 6

Objective

1. To develop bodices with different dart placement through dart manipulation
2. To test fit the same.

Principles

Dart manipulation is a useful tool for the pattern maker to create interesting, innovative dart placements and style lines.

The change in the position of the darts creates interest in the garments in different dart positions.

The same can be magnified by using similar technology on striped fabrics where darts can give a new dimension to the striped patterns.

Darts can be stitched as new darts, as style lines, can be converted into tucks, pleats, gathers, yokes, etc.

The basic fit of the garment is not altered by these manipulations.

Requirement

Pattern paper, muslin and tool kit

Procedure

SLASH AND SPREAD METHOD

In the Slash and Spread method, as the name implies, the pattern/sloper is slashed or cut on the desired line and as the old dart or excess is closed, the pattern itself spreads on the new position to create the new design. Some of the new dart positions are illustrated here:



Design

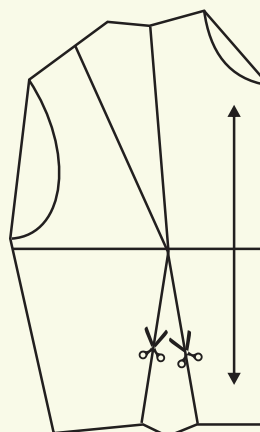

Basic Block

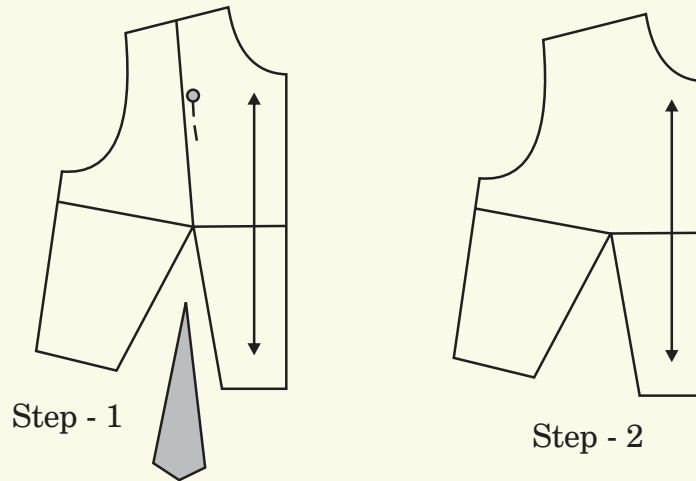
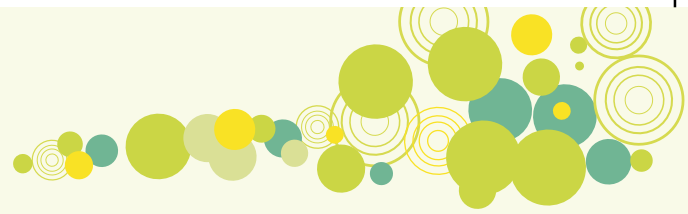

1. Shoulder dart to waist

Take two dart basic block, slash the new dart position i.e. the waist dart. Fold and close the shoulder dart. Trace the new pattern on separate sheet.

2. Waist dart to centre front

Take one dart bodice block. Slash the new dart position, close the old dart. Trace the pattern on separate sheet.

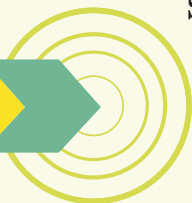
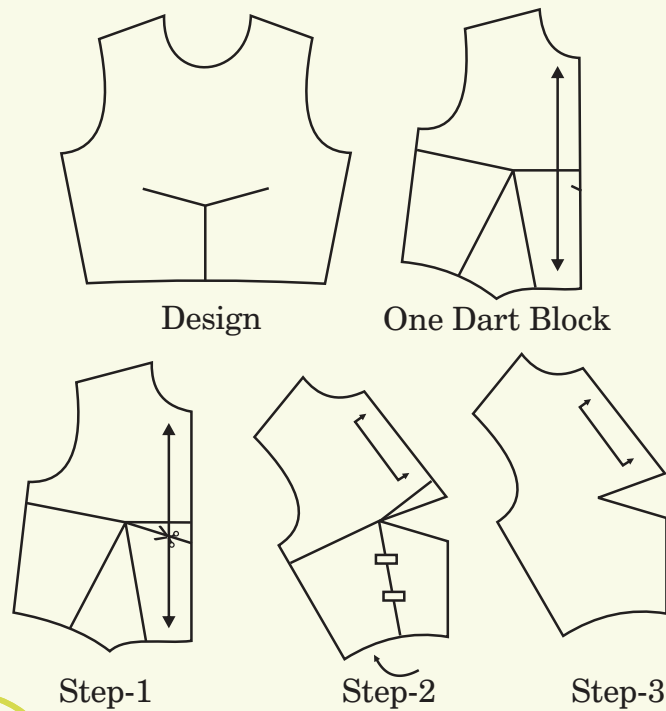



3. Shoulder dart to armhole side seam intersection

Take two dart basic bodice block. Slash the new dart position, close the old dart. Trace the pattern on separate sheet. Shoulder dart to armhole side seam intersection.



Design

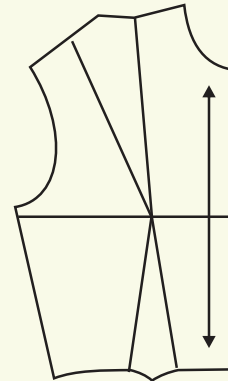

Basic Block

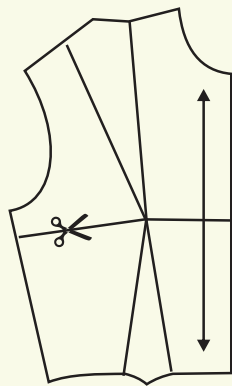

Step-1

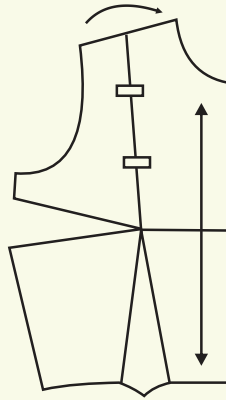

Step-2

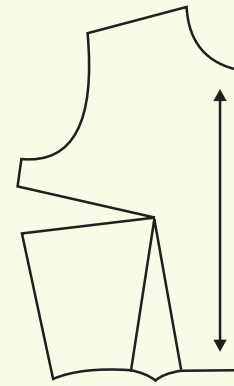

Step-3

Observations

You are required to test fit the developed dart manipulations and check the fit on muslin. Make necessary changes if any.

Viva questions

1. Why is dart manipulation important?
2. What are the things to be kept in mind while using slash and spread method?
3. Does the garment fit as well as the basic block if not what could be the reasons?

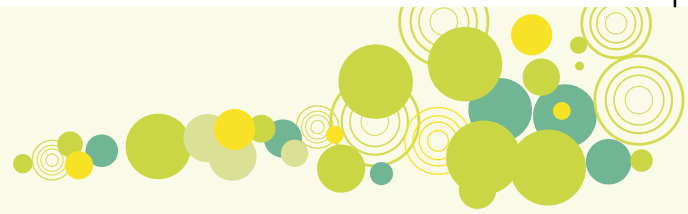

PRACTICAL EXERCISE -7

Objective

To develop a basic skirt and test fit the same

Principles

The basic skirt falls straight downward from the widest part of the hipline. The key to a balanced pattern and garment lies in the accurate placement of the balance line on the dress form and pattern. Any deviation of the balance line between the front and back skirt at the side seam will create fitting problems.

Requirements

Pattern paper, muslin and tool kit

Procedure

To develop pattern for basic skirt for women wear use measurements from the given chart or measure a dress form or a body. Take a paper, whose length is desired length of the skirt plus 3" and width is half of the round hip plus 4".

Make a block A B C D E F, where

A to B = back hip (+1/4" ease to be added if measured on dress form/body)

B to C = front hip (+1/4" ease to be added if measured on dress form/body)

A to D and C to F = Desired length, e.g. 21".

A to G = C to H = 7", hip level

Joint G to H. Mark I at side seam

B to B₁ and B to B₂ = 3/4"

Mark I₁, 2" above I.

Passing through B₂ and B₁, join I₁ J and I₁ K extending it 3/8" above the waistline, as illustrated using hip curve.

A to A₁ = 1/4"

Join J to C, K to A₁ as illustrated, using hip curve.

Measure J to C, K to A₁ and note the measurement on paper, from this measurement subtract the front and back waistline measurement respectively.

The difference is the dart intake for both front and back.

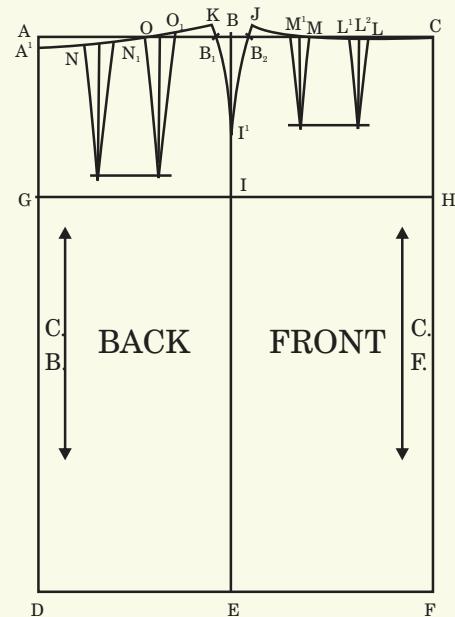

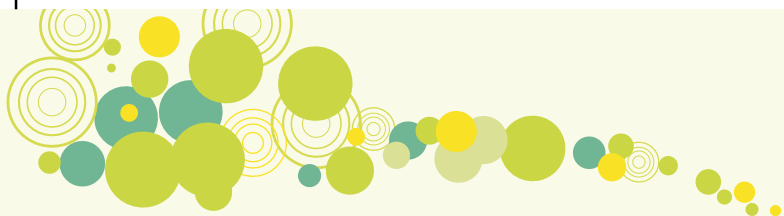

Divide this excess into two darts for both front and back.

Draw a guide line parallel to the waist line at a distance of $3\frac{1}{2}$ " for front and $5\frac{1}{2}$ " for the back,

Mark C to L = Centre front to princess line measurement

L to L¹ = 1st dart ($\frac{1}{2}$ of the total dart intake for front)

L² is mid point of L, L¹.

L¹ to M = $1\frac{1}{2}$ "

M M¹, = 2nd dart ($\frac{1}{2}$ of the total dart intake)

Mark A¹ N = Centre back to princess line measurement

N to N¹ = 1st dart ($\frac{1}{2}$ of the total dart intake for the back)

N¹ O = $1\frac{1}{2}$ "

O to O¹ = 2nd dart ($\frac{1}{2}$ of the total dart intake)

Find the mid-point of all the darts and draw a perpendicular line till the guideline. Join these points to the dart point to form the dart legs.

Trueing

Fold the dart at vanishing point and true the waistline as illustrated raising the waistline by $\frac{1}{4}$ " - $\frac{1}{2}$ " (when you true the waistline with the help of French curve it automatically goes up) at the side seams. Drop back waist line by $\frac{1}{8}$ " at centre back.

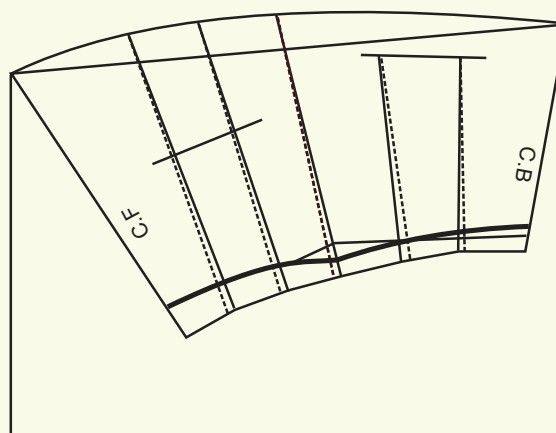

Observations

1. Test fit the developed skirt block.
2. Make necessary changes if any and make the final pattern

Viva questions

1. What are the important measurements for development of skirt block?
2. How do you ensure that the skirt is fitting well?

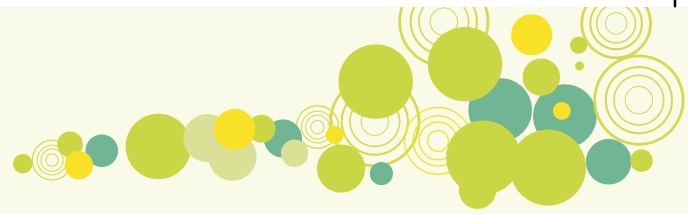

PRACTICAL EXERCISE -8

Objective

To develop style variations in skirt and test fit the same.

Principles

Variations in skirt can be treated through dart manipulation which you have learnt earlier. It is a useful and interesting method for creating interesting, innovative style lines. The change in the position of the darts creates new styles like an A-line skirt and flared skirt. The suppression of the darts is converted into fullness at the hem. The basic fit of the garment is not altered by these manipulations.

Requirements

Pattern paper, muslin and tool kit

Procedure

1. One dart basic skirt

Use a basic skirt sloper that has two darts. Measure the dart towards the side seam and add the measurement to the 1st dart i.e. towards the centre front or back and eliminate the 2nd dart. Note that the length of new waistline dart in the front is $5\frac{1}{2}$ " same as the back dart length. Find the mid-point of the new dart and mark the centre and true the waistline. This method is called measurement method and can only be used in skirts/trousers, as there is no apex in lower half of the body.

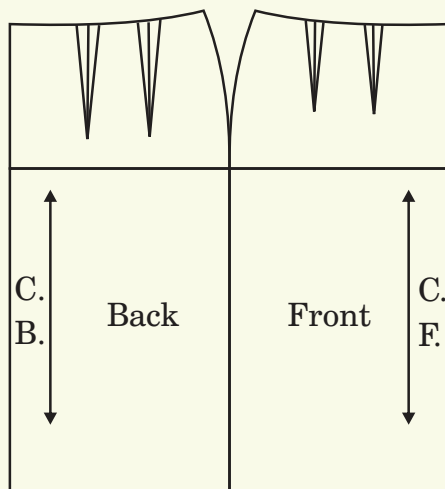

Fig.1

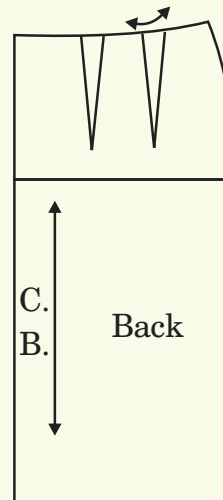

Fig.2 (a)

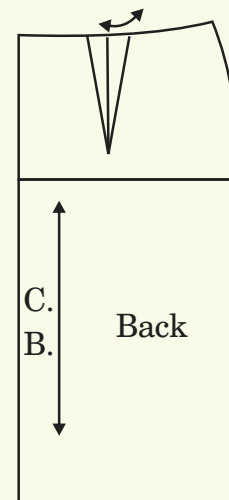
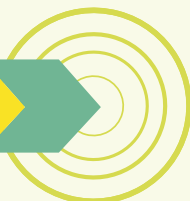

Fig.3 (a)



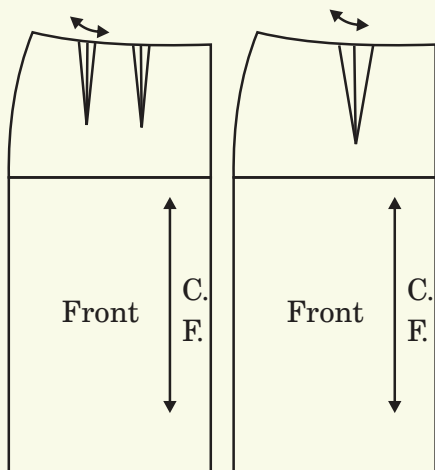

Fig. 2(b)

Fig. 3(b)

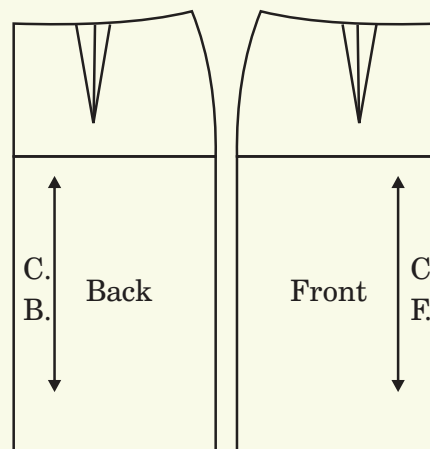

Fig. 4

One Dart Basic Skirt

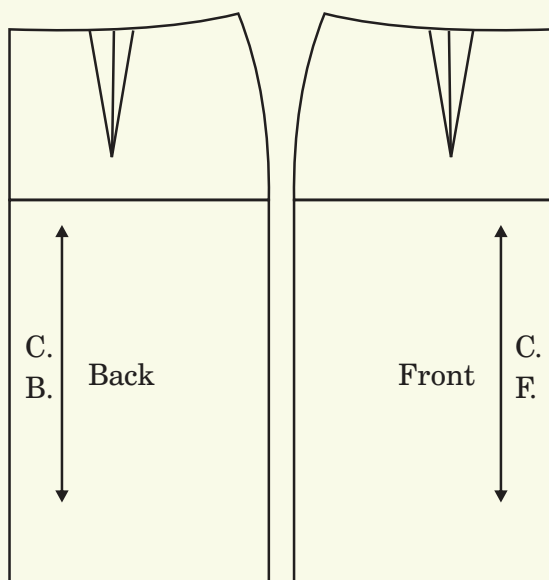

Fig. 1

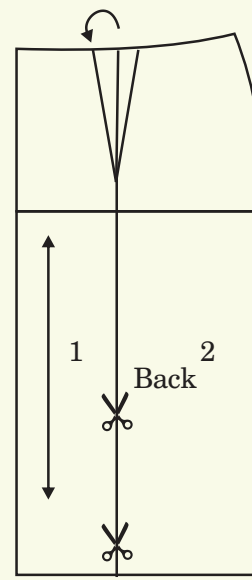

Fig. 2

2. A-Line

1. Take a one dart skirt sloper and draw a slash line as illustrated (fig.2).
2. Slash the line and close a part of the waist dart, so that the ease is shifted to the hem.
3. Add 1" - 1 ½" on the side seam at hem line for A-line shape in the skirt as illustrated.
4. Blend till the hip level for both front and back and also blend the waistline.

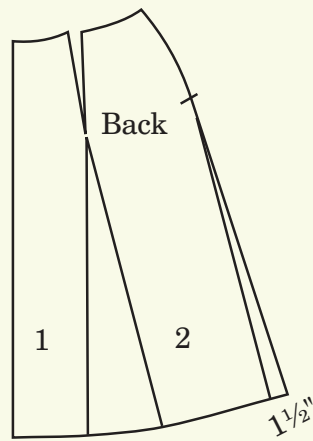
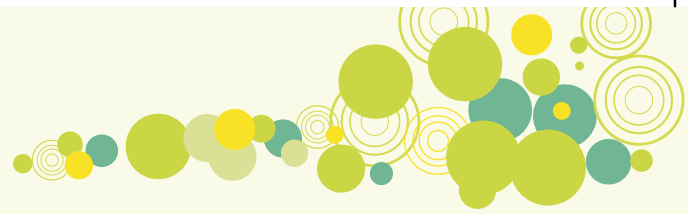

Fig. 3

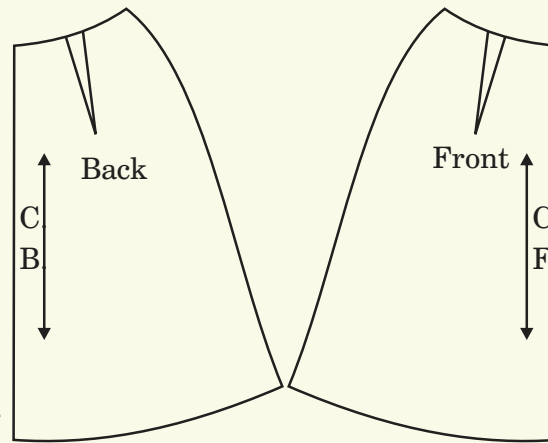

Fig. 4

A-Line Skirt

Observations

You are required to test fit the developed skirt variation and check the fit on muslin. Make necessary changes if any.

Viva questions

1. How is measurement method used for converting two dart skirt sloper into one dart skirt sloper? Is it ineffective for dart manipulation in bodice and why?
2. Which other skirt design variations are possible through dart manipulation?

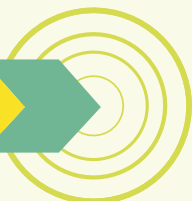



ANNEXURE - I

Tool Kit

- All pins** : Fine, long, rust proof pins.
- Carbon paper** : Coated paper on one side with white or coloured wax, used to transfer marking on fabric or paper.
- Dress form** : A standardized duplication of a human torso, cotton padded and canvas covered, set on a movable, light adjustable stand and compressible shoulders and slopers. For taking measurements, developing pattern, fitting garment samples, to alter garments to establish style lines for the garment.
- Grading scale** : 2" X 18" transparent straight plastic with grid
- L-square** : Plastic or metal ruler with two arms at right angles of varying lengths usually 12" and 24" to square off corners. Establish perpendicular lines, reference points and lines.
- Magnet** : A high carbon alloy steel that has a property of attracting iron and steel can be of any shape.
- Measuring tape** : Metal tipped narrow, firmly woven double tape of cloth or plastic usually 60" long (150cm) marked with both inches and centimeters.
- Muslin** : A plain weave fabric made from bleached or unbleached yarns to test fit and develop patterns.
- Newsprint paper** : Used for rough drafts.
- Paper shears/scissors** : A cutting instrument, ranging in size from 8" to 12", with two sharply pointed straight blades.
- Pattern paper** : Strong white paper available in variety of weights and widths.
- Pencil** : To mark lines in developing the muslin, pattern or sloper.
- Pin cushion** : A small firmly stuffed pillow made in a variety of shapes and sizes.
- Push pins** : Drum shaped 1/2" long pin for pivoting and transferring points & to hold pattern pieces and fabric on table.



FASHION STUDIES



- Scale** : Long ruler 12" / 24" metal or plastic.
- Tailors shears** : A cutting instrument ranging in size from 12" to 16" with two wide blades for cutting fabric and muslin.
- Thick brown paper** : Strong brown papers for finished pattern. Used for preliminary patterns drafting and development of the final pattern.
- Tracing wheel** : An instrument with small serrated or needle point wheel mounted on one end of a handle for transferring markings from paper patterns on the muslin.
- Transparent tape** : A clear plastic narrow continuous stripes with an adhesive surface on one side, available in roll. Used to hold paper pieces and mend tears.

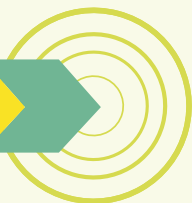

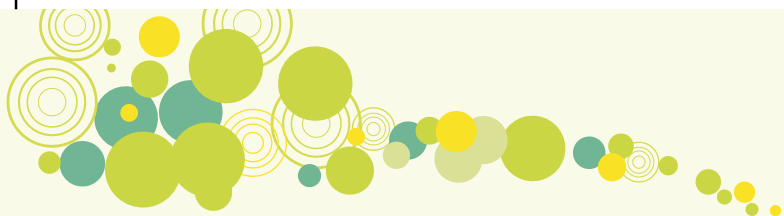

ANNEXURE - II

STANDARD DRESS FORM MEASUREMENT CHART FOR BODICE & SKIRT (in inches)

SIZES	32	34	36	38	40	42	44
FRONT LENGTH	17 ^{1/4}	17 ^{1/2}	17 ^{3/4}	18	18 ^{1/4}	18 ^{1/2}	18 ^{3/4}
WIDTH OF BUST (1" below arm plate includes an ease of 1/2")	9 ^{1/2}	10	10 ^{1/2}	11	11 ^{1/2}	12	12 ^{1/2}
CENTRE FRONT LENGTH	14 ^{3/8}	14 ^{1/2}	14 ^{5/8}	14 ^{3/4}	14 ^{7/8}	15	15 ^{1/8}
APEX	3 ^{5/8}	3 ^{3/4}	3 ^{7/8}	4	4 ^{1/8}	4 ^{1/4}	4 ^{3/8}
UNDER ARM SEAM	7 ^{7/8}	8	8 ^{1/8}	8 ^{1/4}	8 ^{3/8}	8 ^{1/2}	8 ^{5/8}
FRONT WAISTLINE (includes an ease of 1/4")	6 ^{3/8}	6 ^{3/4}	7 ^{1/8}	7 ^{1/2}	7 ^{7/8}	8 ^{1/4}	8 ^{5/8}
WAISTLINE TO SHOULDER (includes an ease of 3/4")	14 ^{3/4}	14 ^{7/8}	15	15 ^{1/8}	15 ^{1/4}	15 ^{3/8}	15 ^{1/2}
SHOULDER LENGTH	4 ^{7/8}	5	5 ^{1/8}	5 ^{1/4}	5 ^{3/8}	5 ^{1/2}	5 ^{5/8}
CENTRE FRONT TO PRINCESS LINE	2 ^{5/8}	2 ^{3/4}	2 ^{7/8}	3	3 ^{1/8}	3 ^{1/4}	3 ^{3/8}
WIDTH OF BACK (1" below arm plate includes an ease of 1/2")	8 ^{1/2}	9	9 ^{1/2}	10	10 ^{1/2}	11	11 ^{1/2}
CENTRE BACK LENGTH	16 ^{1/2}	16 ^{3/4}	17	17 ^{1/4}	17 ^{1/2}	17 ^{3/4}	18
BACK WAIST LINE (includes an ease of 1/4")	5 ^{5/8}	6	6 ^{3/8}	6 ^{3/4}	7 ^{1/8}	7 ^{1/2}	7 ^{7/8}
SHOULDER BLADE	6 ^{7/8}	7	7 ^{1/8}	7 ^{1/4}	7 ^{3/8}	7 ^{1/2}	7 ^{5/8}
CENTRE BACK TO PRINCESS LINE	2 ^{1/2}	2 ^{5/8}	2 ^{3/4}	2 ^{7/8}	3	3 ^{1/8}	3 ^{1/4}
FRONT HIPLINE (7" below waistline)(includes an ease of 1/4")	9 ^{1/8}	9 ^{3/8}	9 ^{5/8}	9 ^{7/8}	10 ^{1/8}	10 ^{3/8}	10 ^{5/8}
BACK HIPLINE (7" below waistline) (includes an ease of 1/4")	9 ^{1/8}	9 ^{3/8}	9 ^{5/8}	9 ^{7/8}	10 ^{1/8}	10 ^{3/8}	10 ^{5/8}
CAP HEIGHT	6	6	6	6	6 ^{1/8}	6 ^{1/8}	6 ^{1/8}
SHORT SLEEVE LENGTH	9	9 ^{1/4}	9 ^{1/2}	9 ^{3/4}	10	10 ^{1/2}	10 ^{3/4}
SLEEVE LENGTH	23	23 ^{1/2}	24	24 ^{1/2}	24 ^{1/2}	25	25



ANNEXURE - III

Test Fitting

Steps of test fitting are as follows:

1. Muslin is usually used as test material
2. The quickest way to get the effect of the finished garment without actual stitching is to overlap and pin all the seams lines. Pinning gives the same result and information, that one wants without going to the machine. It is so much faster and easier to unpin and then re-pin than to rip stitching and re-stitching.
3. Pins should be placed at right angle to the seam line, as in this method there is least amount of strain or pull on the seam, and it does not gape.
4. Check the test fit muslin and make correction till fully satisfied.
5. Mark the necessary corrections and the same should be transferred on the paper pattern for a final pattern of the garment.



Chapter 3

Elements of Fashion

PRACTICAL EXERCISE - 9

Objective

1. To enable students to develop an eye for detail and to create compositions
2. To enable students to design products with self-generated prints, inspired from nature.

Objective: Creating prints from Flora and Fauna.

Material Requirement:

1. Poster Paints
2. Brushes
3. Fabric paint
4. A4 size cartridge / ivory paper
5. Cotton Dupatta / scarf (20" X 20")

Procedure:

1. Take a nature walk to collect leaves/ twigs/ flowers etc.
2. Apply poster paint/s on one side of the leaf /twigs/flower selected.
3. Create impressions on paper by the painted leaf /twigs/flower.
4. Use the impressions in multiple forms to create a motif.
5. Get the motifs approved by the subject teacher.
6. Use fabric paint and the approved motif to create prints on cotton Dupatta /scarf.

Observation and Discussion:

1. Students are to explain the process by maintaining a scrap book.
2. The product designed by the student can be discussed in the class for the views of the other students and overall feedback at the class.

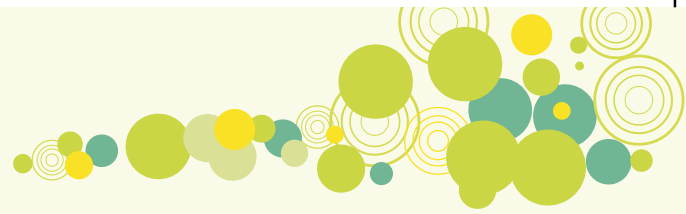

PRACTICAL EXERCISE -10

Objective:

1. To explore the patterns created by using food products for dyeing process.
2. Creation of resist prints using organic dye bath, obtained from food items.

Material Requirement

1. Tea/ Coffee/ turmeric powder (3 tsps)
2. White Cambric fabric (10 inch X 10 inch)
3. Steel Container for dye bath
4. Gas stove
5. Thick Cotton thread for tying fabric
6. Needle and thread

Exercise Procedure:

Pre Dyeing Procedure

Take the fabric squares and tie them with thick cotton thread through following methods:

- ❁ Option 1: Tie the fabric starting from the center in circular patterns till the edge.
- ❁ Option 2: Spreading tied circles throughout the fabric like all over dots.
- ❁ Option 3: Diagonally fan-fold the fabric and then tie thick yarn in $\frac{1}{2}$ inch gaps.
- ❁ Option 4: Using needle & thread to stitch parallel lines on the fabric.

Pull the string to tie them tight to get an effect.

Dyeing Procedure

1. Create a dye bath by boiling turmeric powder/ tea/ coffee in water in a steel container.
2. Once the dye bath boils, put the tied fabric bundles prepared in the above procedure and let them boil in the prepared bath for 10-15 minutes.
3. Open the threads and let them dry to see the effect.
4. The 10 inch x10 inch swatches can be joined together to create an interesting blanket.

Observation and Discussion:

1. Observe how various tying techniques creates different patterns on the fabric.
2. Students are to explain the process by maintaining a scrap book.
3. The product designed by the student can be discussed in the class for other students to view, and discuss feedback.

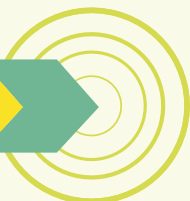

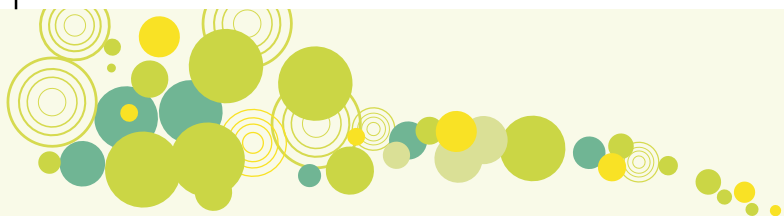

PRACTICAL EXERCISE - 11

Objective

1. To observe elements of design in nature.
2. To develop print designs inspired from animal skin by using various materials innovatively.

Materials Requirement:

1. A4 size ivory paper / Catridge paper
2. Glue/ fevicol
3. Cotton wool
4. Cotton strings
5. Colored pastel paper
6. Poster Paints
7. Brushes
8. Pencils
9. Eraser

Exercise Procedure:

1. Collect pictures of animals with distinct skin patterns.
2. Sketch the outline of the animal skin print like zebra stripes, giraffe patches, leopard dots etc. on a paper.
3. Innovatively create the animal print using Cotton wool, Cotton strings, Colored pastel paper and Poster Paints.
4. Use the developed print to create a bag/ a tie with this distinct pattern.

Observation and Discussion:

1. Observe the various animal skin prints.
2. Students are to explain the process by maintaining a scrap book.
3. The product designed by the student can be discussed in the class views, explorations and selection of final concept by the students & class.

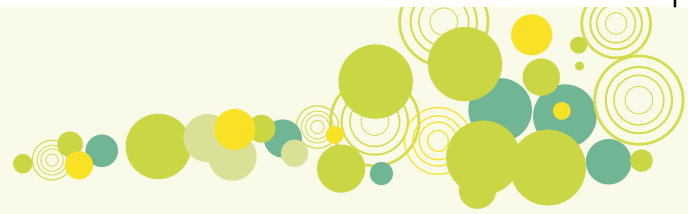

PRACTICAL EXERCISE - 12

Objective

1. To explain the stencil printing technique
2. To create stencils for achieving design patterns.

Materials Requirement:

1. A4 size ivory paper
2. Brushes
3. Pencils
4. Eraser
5. Stenciling card (any medium weight paper)
6. Poster paints
7. Paper Cutter
8. Old Tooth brush

Exercise Procedure:

1. Draw a design on a card with a pencil.
2. Cut out the shape using a paper cutter.
3. Place the stencil on the paper.
4. Paint over the hollow cut out design on paper.
5. Repeat the process to get a painted border.
6. Instead of Solid paint, spray paint technique can be used by using an old tooth brush)
7. Create any one product using the above technique:
 - ✿ A Handkerchief
 - ✿ A painting
 - ✿ A card
 - ✿ A book cover

Observation and Discussion:

1. Students are to explain the process by maintaining a scrap book.
2. The product designed by the student can be discussed in the class for views, explorations and selection of final concept by the students & class.

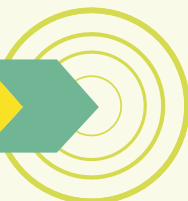

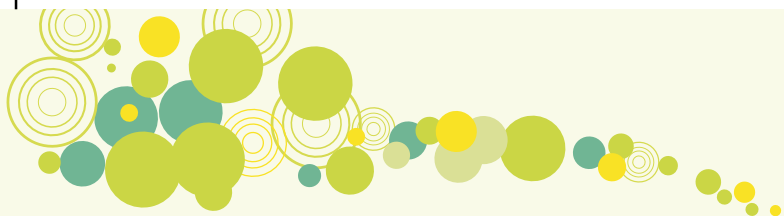

Chapter 4 *Basics of Garment Making*

Introduction

This course is in continuation of the course in class XI. Advanced skills required for converting fabrics into a stitched garment with value addition are covered in this year's curriculum. The emphasis is on how to finish the openings and on assembling of complete garment.

Basic Preparation

Prior planning and clarity is necessary for the performance of the exercises.

Read handouts, appropriate lab manuals and textbooks before performing the practical.

Follow all precautions and regulations while working in the lab.

Listen carefully to any introductory remarks and experimental procedure given by your teacher.

Make sure that your working space is clean and organized, and all the required stocks and materials are kept ready.

Maintain discipline in your working area.

Recording Practical Results

Practical results should be recorded in the recommended record/file neatly and legibly with great care. The record of exercises may be done under following headings:

1. Introduction/Aim

State precisely the purpose and objectives of the experiment in two or three sentences.

2. Materials and methods

The requirements such as equipment, materials, etc. should be given here. Apart from this, methods should also be described along with principles of the techniques used.

3. Sample/ Results

The sample should be attached here.

4. Discussion and Conclusions

Here, the results should be interpreted and conclusions be drawn.

5. References

Reading material that was consulted for the experiment should be given as reference (e.g. your lab manual) along with the name of the author and the book, pages referred to and year of publication.

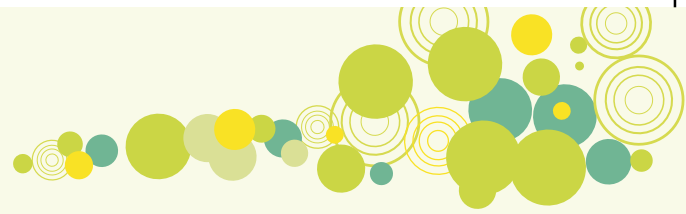

Safety rules in the laboratory

- ❁ Safety rules to be observed while working on the machine: Safety is important to everyone and it is one's responsibility to maintain a safe working place.
- ❁ When operating the machine, do not be careless.
- ❁ Always inspect the machine before starting work. Be sure it is clean and threaded correctly, with no loose threads on the pulley belt and all guards in place.
- ❁ When in doubt, ask the teacher.
- ❁ Report any injuries or accidents immediately to the teacher.
- ❁ Wipe up any oil spilled on the floor immediately to prevent anyone from slipping.
- ❁ Operate machines only with permission.
- ❁ When sewing on a power machine, wear low heel shoes and close-fitting clothing. Avoid loose-fitting sleeves, sweaters, jewellery, ties and ribbons when operating the machine. If your hair is long, tie it at the back.
- ❁ Do not tilt your chair forward or backward while operating the machine.
- ❁ Use both hands to raise and lower the machine head.
- ❁ Always keep your head above the table.
- ❁ Keep your feet off the treadle when you are not operating the machine.
- ❁ Keep your feet off the treadle when you are setting or threading the needle.
- ❁ Turn the motor off when you are not stitching.
- ❁ Turn the motor off before cleaning, oiling or adjusting the machine.
- ❁ Turn the motor off before removing or replacing the pulley belt and run the machine out. Wait until all motion has stopped.
- ❁ Turn the motor off in case of an emergency or when in doubt.
- ❁ Turn the motor off before unplugging the machine.
- ❁ Do not use your hand to stop and start the hand wheel.
- ❁ Use your hand only to set the hand wheel.
- ❁ Before operating the machine, close the slide bed cover. When operating the machine, keep your hands, scissors and other sharp objects away from the belt.
- ❁ Keep the machine and work station clean with all tools in the side drawer.
- ❁ Unplug the machine at the end of the day.

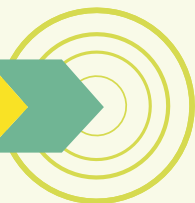



- ❁ Know the location of the main power switch, outlets and fuses in case of an emergency.
- ❁ Do not remove any safety devices from the machines.
- ❁ Turn off the iron at the end of the class.
- ❁ Always place the iron on the iron pad to avoid burning the ironing board cover.
- ❁ When trimming or cutting, put all trimmings in the wastebasket.
- ❁ Scissors should be handed to another person with the handles toward the person.
- ❁ Never toss or throw scissors or equipment.
- ❁ Do not eat or drink in the work area.
- ❁ Keep your machine covered when not in use.

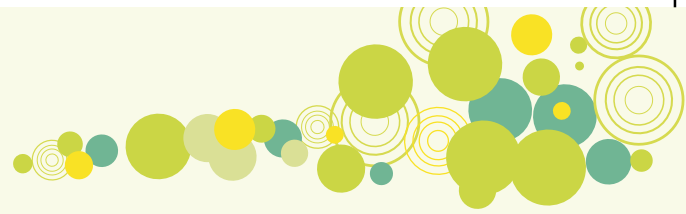

PRACTICAL EXERCISE - 13

Objective

Stitch a continuous placket sample.

Principles

A placket is a finishing provided to an opening in a garment. It should be designed and styled in sufficient length to permit ease and convenience of dressing.

Placket openings are used on sleeves, front or back neckline to allow for ease in wearing a garment.

Plackets are planned as an extension for placement of buttonholes, snaps and other fasteners.

Some plackets have buttons and buttonholes while others do not.

When designed for neckline openings, the placket can end at the neck edge or extend beyond the neck and become part of the collar.

The measurement can vary to create different effects.

The type and length of placket selected depends on:

- ❖ Placement of placket.
- ❖ Function of placket.
- ❖ Style and design of garment.
- ❖ Use of garment.
- ❖ Type and weight of fabric.
- ❖ Care of garment.
- ❖ Method of construction.

A Continuous placket is easy to make and serves as the basis for a number of variations. It is a one-piece placket that is widely used on cuffed sleeve openings to permit the hand to fit through sleeve circumferences, bloomers, children's dresses, skirts, trousers etc., where zipper application would detract from appeal of the garment and in neckline openings as an alternative to other fasteners or closures.

Requirements

Machine & sewing kit (as given in Annexure I)

Pre Lab Preparation

Student should be familiar with the safety rules.

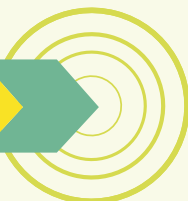



Cut the pattern piece for length of the piece. Take double the length of the finished placket opening and add 1" extra. (The 1" extra length of the binding strip is for emergency only. If measurements are accurate and the placket is properly made, this amount should be cut off after the binding is stitched in place.) The width of the piece will be twice the width of finished placket facing (which is usually $\frac{1}{2}$ " for 1 side) plus two times seam allowances (which usually is $\frac{1}{4}$ "

PATTERN PIECES

2 X length of finished placed + 1"

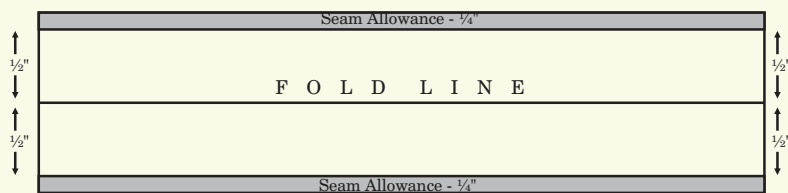

CONTINUOUS PLACKET

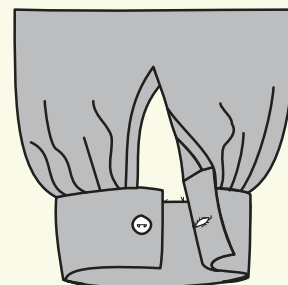

Procedure

1. Place the right side of the placket on the wrong side of the sleeve opening and start stitching near the edge leaving a distance of $\frac{1}{4}$ ". As you come to the center of the placket, maintain $\frac{1}{4}$ " seam allowance of placket piece and reduce the allowance of the garment piece. Take care so that no pleat formation takes place at this point.

CONTINUOUS SHIRT PLACKET

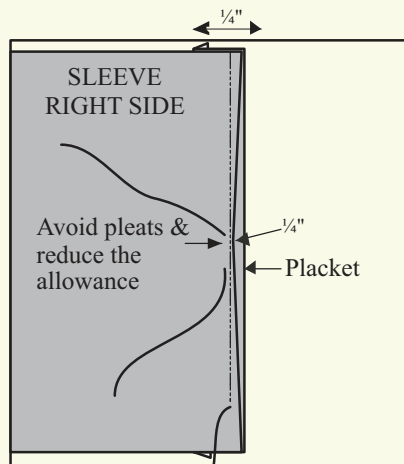

Step-1

2. Fold the allowance (other side) of the placket and place it on first stitching line. Then stitch in place from right side of the sleeve. Take care that stitching at the back is the same i.e. if it



is on top, it should be maintained on top throughout and if it is in ditch then maintain it throughout. In good quality plackets, this seam is on top at the back.

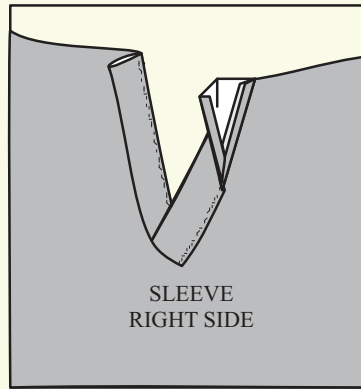

Step-2

3. From the wrong side of the sleeve, stitch both the upper and under of the placket, two to three times diagonally (at 45°) near end. This is known as Bar Tack.

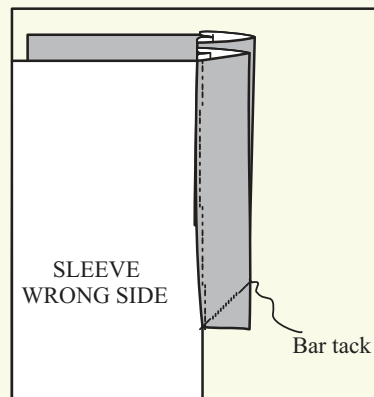

Step-3

Observations

The placket should be finished neatly and close properly with both ends on top of each other. The buttons should not gape open, especially near the bust.

Viva Questions

1. What purposes this placket used for?
2. What is the importance of a bar -tack?

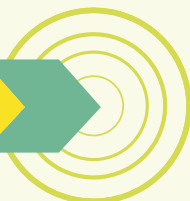



PRACTICAL EXERCISE - 14

Objective

Stitch a basic shirt placket sample.

Principles

A basic shirt placket is an extension placket where buttons and buttonholes are placed on the facing which is created by extending the center front on both sides.

Requirements

Machine & sewing kit (as given in annexure I)

Pre Lab Preparation

2 Pattern pieces required - one for the upper part and the second for the under part.

Upper Part

- Trace the bodice till the Centre Front line.
- Mark the extension which can be:
 - ❁ Half the button + 1 cm i.e. Radius of the button + 1cm.
 - ❁ Diameter of the button.
 - ❁ A standard measurement of $\frac{1}{2}$ " or $\frac{3}{4}$ " as taken for men's shirts.
- The line of extension is the fold line. Make a standard facing of $1\frac{1}{2}$ " with an allowance of $\frac{1}{4}$ ".
- Turn the allowance towards wrong side of the facing.
- Turn the fold line towards wrong side of the garment piece. (If facing has to be aligned to the selvedge when placed on fabric then no seam allowances is taken).
- Cut out the pattern.

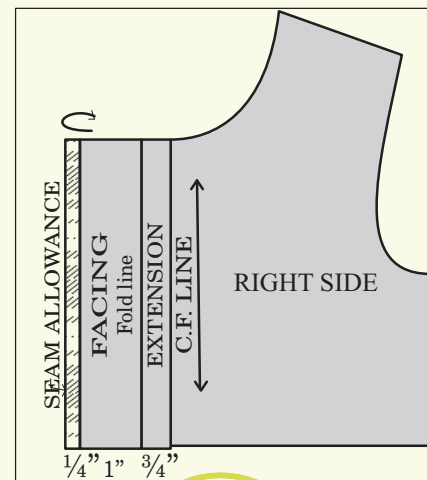
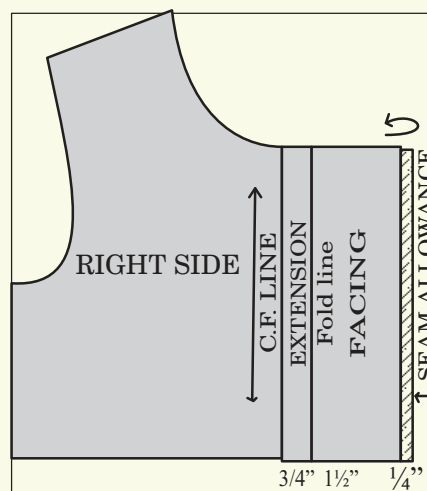

Under Part

- Flip the pattern horizontally and trace it.
- The under part is made in the same way as the over part. The difference is the facing, which is 1". Otherwise stitching line of under part will be visible on the front of the placket.

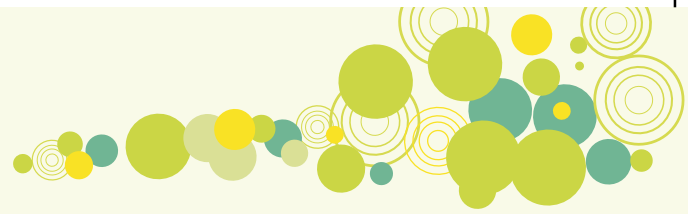

Procedure

Upper Part

1. Trace the pattern on the fabric and mark the position of the lines.
2. Turn the allowance towards the wrong side of the fabric.
3. Turn the facing also in the same way from the fold-line i.e. towards wrong side of fabric.
4. From the wrong side of the fabric, stitch on the edge of facing as illustrated.

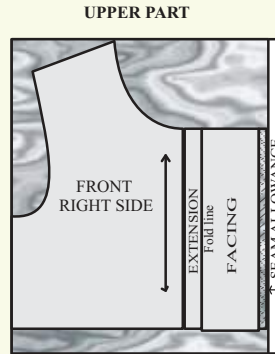

Step-1

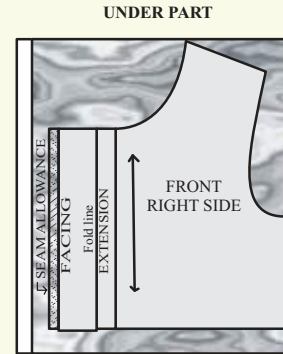

Step-1

Under Part

1. Trace the pattern on the fabric and mark the position of all lines.
2. Turn the allowance towards wrong side of the fabric. In same way turn the facing also.
3. From the wrong side of the fabric, stitch on the edge of facing as illustrated.

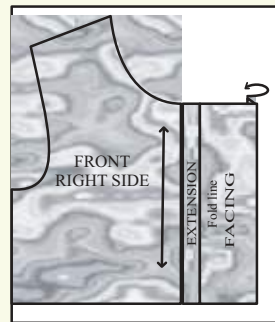

Step-2

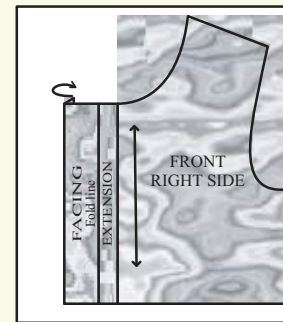

Step-2

Observations

1. The placket should be finished neatly and close properly with edges neatly on top of each other.
2. The buttons should not gape open, especially near the bust.

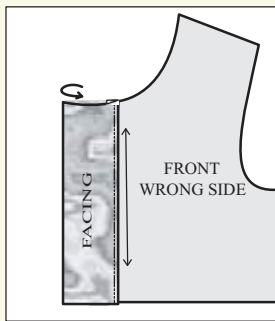

Step-3

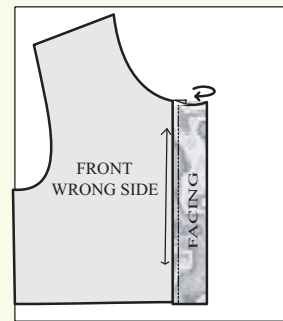

Step-3

Viva questions

1. What are the factors on which the width of the placket depends?
2. Apart from the shirt where can this placket be used?

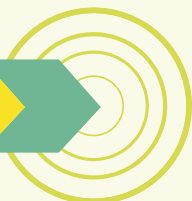



PRACTICAL EXERCISE -15

Objective

Stitch a sample of shirt placket with facing.

Principles

The shirt band/the strip on the right side of shirt front in which the buttonholes are made, eliminates the need for facing.

An extended self-facing is used on the left front.

The finished shirt band is 1½" wide but construction techniques vary depending on the fabric and style of the shirt.

Requirement

Machine & sewing kit (as given in annexure I)

Pre Lab Preparation

Under Part

Trace the bodice and make extension of ¾" which is half of finished placket. Keep an allowance of ¼".

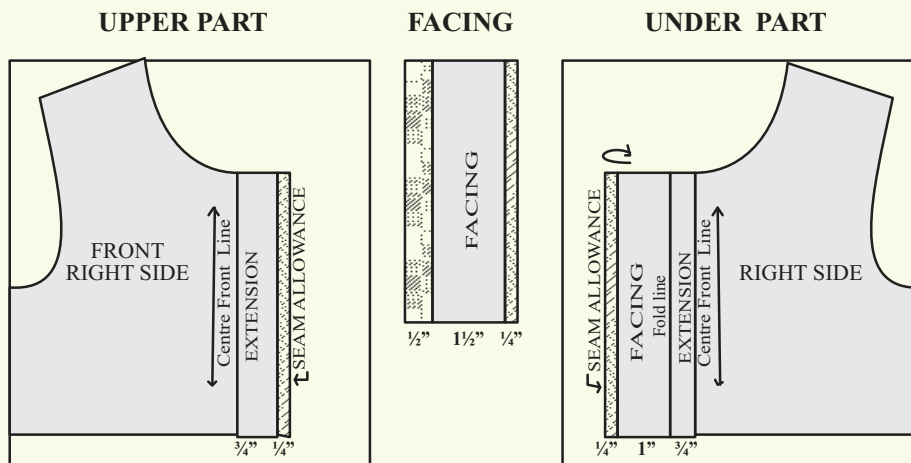

Facing

A straight strip of the length same as placket opening is taken. Mark ¼" seam allowance on one side and ½" seam allowance on the other side.

Under Part

Flip and trace the other half of bodice and mark extension of ¾" and facing of 1" then mark the seam allowance of ¼".

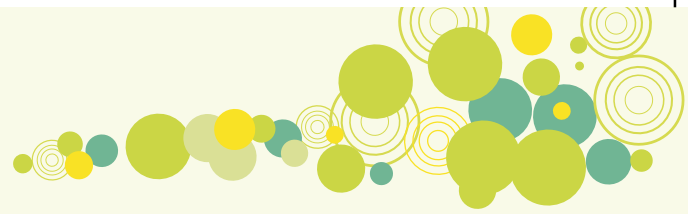

Procedure

Upper Part

1. Place right side of the facing over wrong side of garment piece and then stitch leaving the $\frac{1}{4}$ " allowance near edge.
2. From right side of the fabric, turn facing towards right side. Press the seam allowance ($\frac{1}{2}$ " of facing towards wrong side of facing. Iron in place.
3. Leave allowance of $\frac{1}{4}$ " from both the sides and stitch in place from right side.

Under Part

1. Trace the pattern for under part on the fabric.
2. Fold the seam allowance of the facing towards the wrong side of the fabric.
3. Again turn this facing towards the wrong side of the fabric, stitch in place. (For diagram refer steps of construction for under part of simple shirt placket.)

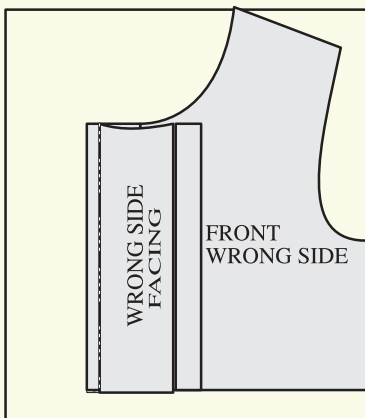

Step-1

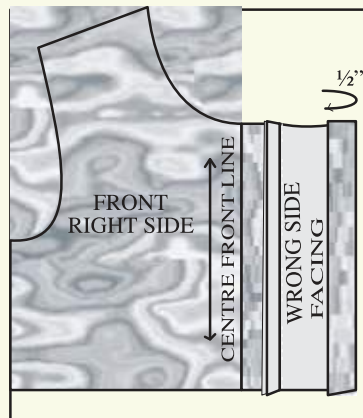

Step-2

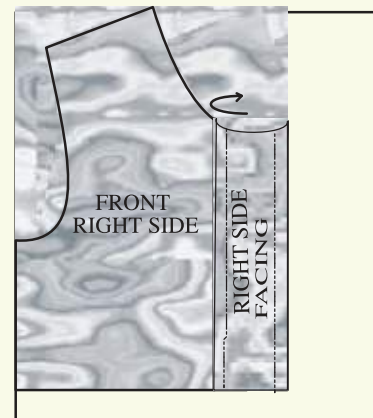

Step-3

Placement of Buttons

The button extension is equal to the width of the button. As a general rule the neckline of the front bodice is lowered by $\frac{1}{4}$ " at the centre front for comfort, whenever a basic neckline is required. The first buttonhole is placed on center front, down from neckline an amount equal to the width of the button. This ensures that the button will not extend into the neck. Placement of the last button hole depends on the need or the requirement of the garment. The rest of the button holes are marked on the even division between the first and the last. It is a good idea to place a button close to the apex or bust point. This ensures that the garment does not gape open at the centre front due to movement, which may cause a pull on the bust.

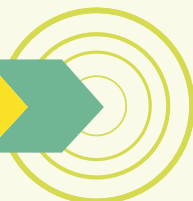

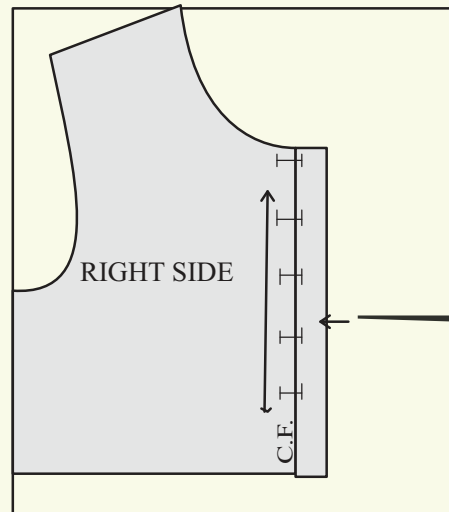

The size of the button hole equals the width of the button plus 1/8" for the button to go in easily. The button hole is marked so that width of the button is on the garment side of the centre front and extra 1/8" is on the extension.

Observations

The placket should be finished neatly and close properly on top of each other. The buttons should not gape open specially near the bust.

Viva questions

1. Give common uses of this placket.
2. At what distance from the neck edge should the first button be placed on the placket?



PRACTICAL EXERCISE - 16

Aim

Stitch a sample each of Extended facing, Bias facing and Shaped facing.

Principles

A Facing is a fabric piece used to finish raw edges of a garment at such locations as neck, armhole and front and back opening. A facing is shaped to fit the edge it will finish either during cutting or just before application.

There are three categories of facings:

- ✿ Shaped facings
- ✿ Extended facings
- ✿ Bias facings

A Shaped facing is cut out, using a pattern, to the same shape and on the same grain as the edge it will finish. A Bias facing is a strip of fabric cut on the bias so that it can be shaped to match the curve of the edge it will be applied to. After a facing is attached to the garments edge, it is turned to the inside of the garment and should not show on the outside.

In order to reduce bulk, both shaped and bias facings can be cut from a fabric lighter in weight than the garment fabric. Since the extended facing is cut as one with the garment, the garment and facing fabric are **generally** the same but sometimes may vary according to the design.

NECK LINES

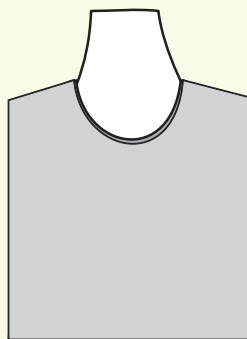

BIAS BINDING

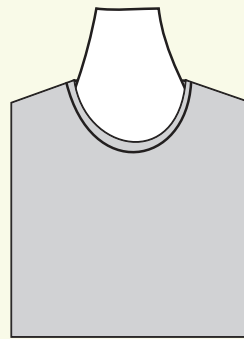

BIAS FACING

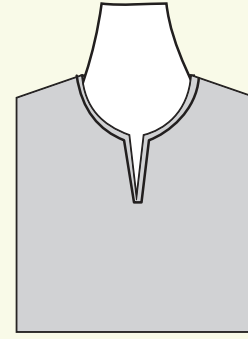

SHAPED FACING

Requirements

Machine & sewing kit (as given in Annexure I)

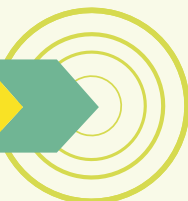



Pre Lab Preparation

Bias Strip

Bias strip is prepared as a strip of matching or contrasting fabric. Bias for binding, piping and tubing is a true bias and is defined as the diagonal line established by a 45° degree angle, intersecting length and cross grain of a square. The bias of the fabric offers the maximum stretch, flexibility, and elasticity needed to conform to a curved edge.

Preparation of Bias Strip

1. Find the true bias of the fabric by folding fabric with lengthwise grain parallel to the crosswise grain. The folded edge is the true bias.
2. After locating true bias, draw the width and the desired number of strips needed for desired length of bias and then cut it.
3. Often the bias strips are not long enough to complete a continuous sewing step. Adequate number of strips must be joined before starting to sew bias binding or facing.
4. Now place the cut out bias strips at right angles, right side facing right side.
5. Stitch bias strips with a ¼" seam allowance at angles.
6. Continue to join bias strips as needed for the desired length.
7. Press all seams open and snip extended points.

Once the strip is ready it can be applied on the neckline

Procedure

A. Neckline Finished with Bias Binding/Extended Facing

A standard bias strip is 1 to ½ inch wide.

Steps of construction

1. Place the garment on sewing table wrong side up. Now place the bias strip on the garment with right side facing wrong side (of garment), matching both the raw edges.
2. Stitch with a ¼" seam allowance.
3. Fold the bias strip over ¼" and use iron instead of press down.
4. Fold bias binding over along stitch line and use iron instead of press down.
5. Fold bias strip over Wrong Side of garment just covering first stitch line.
6. Slip stitch along the edge of bias binding.

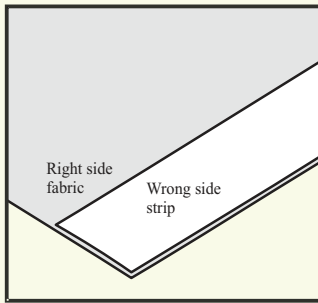
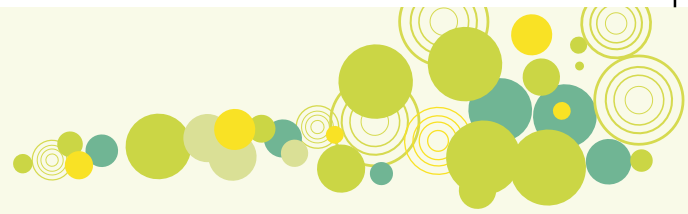

Step -1

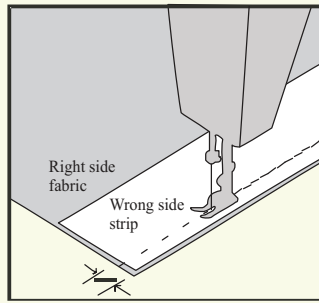

Step -2

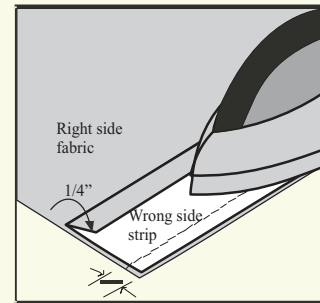

Step -3

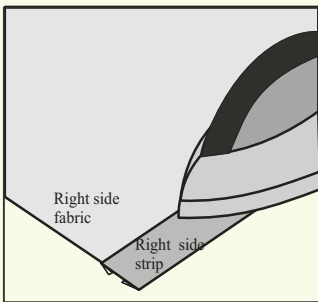

Step -4

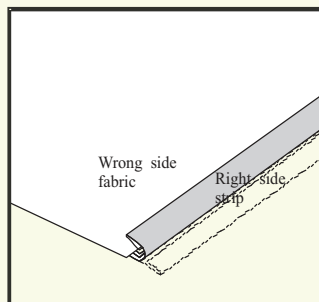

Step -5

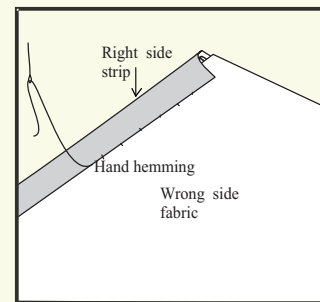

Step -6

B. Neckline Finished With Bias Facing

A bias facing is a strip of fabric cut on the bias which is attached to the garment neckline so that it can be shaped to match the curve of the edge it will be applied to.

After a facing is attached to the garment, it is turned to the inside of the garment and should not show on the outside i.e. right side of the garment.

The finished width of bias facing should not be more than $\frac{1}{2}$ ".

Steps of Construction

1. Face right side of bias strip to the right side of the garment neckline. When applying the binding, fold back the starting end $\frac{1}{2}$ " and align the fold with the garment seam line. Pin binding in place and stitch to within 3" of starting point.
2. Trim away excess binding at this end to $\frac{1}{2}$ " beyond fold of starting end. Lap this end over the beginning fold and stitch the rest of the way across, through all thicknesses. When the binding is turned, the end folded first will be on top; stitch or slip stitch it with the other end.
3. Clip the curved seam allowance.
4. Open the facing away from the garment Iron all seam allowances towards the facing. To keep facing from rolling to the outside of garments, the seam should be under

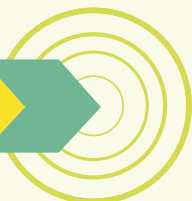



stitched with facing and seam allowance extended away from garment. Stitch from right side close to neck seam line, through facing and seam allowance.

5. Turn the other edge of the facing towards its Wrong Side. Iron and slip stitch.

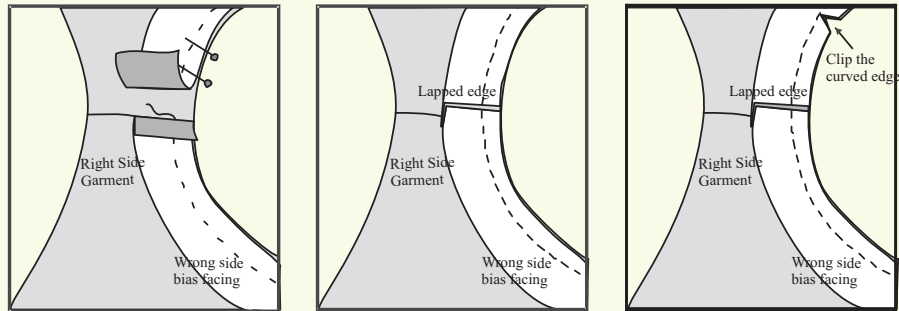

Step -1

Step -2

Step -3

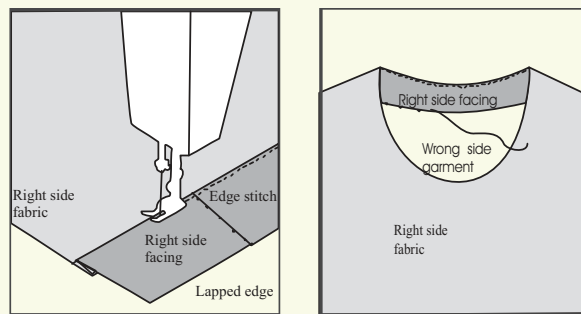

Step -4

Step -5

C. Slit Neckline with Shaped Facing

A neck line shape which is finished with shaped facing i.e. instead of finishing raw edges of fabric at neckline with bias strip as used earlier, it is finished with a facing which is of the same shape as the neckline.

Steps of Construction

Preparation of facing

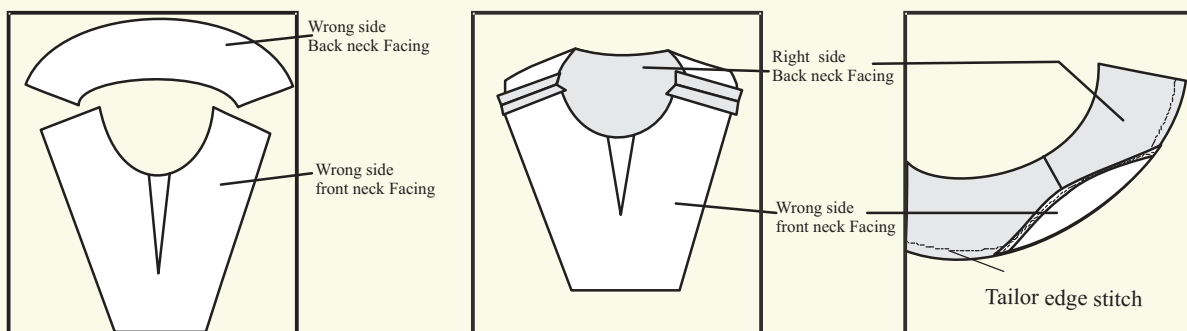

Step -1

Step -2

Step -3

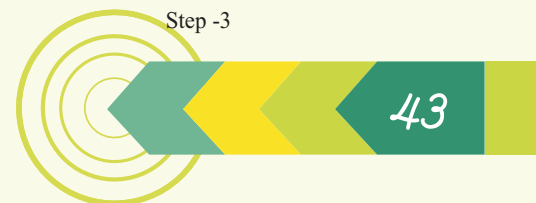

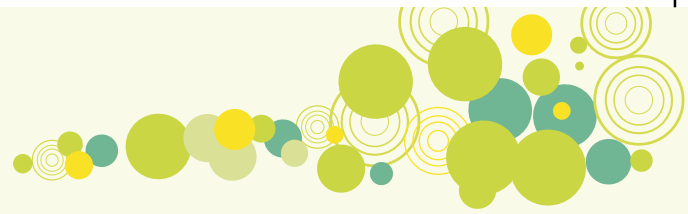

Steps of Construction

1. Interface the wrong Side of the facing of both front back.
2. With Right Side together and the markings matched, seam stitch the front facing sections to the back facing sections at shoulders. Iron seam flat as stitched then open.
3. Keeping seam allowances open, tailor edge finish the facing by turning under 1/8" Iron. Stitch close to folded edge.
4. Right Sides together, matching notches, markings and seam lines, pin facing to neck and machine.
5. Trim diagonally across cross seam allowances at shoulders. Clip curved seams, also slash the opening at front neckline and clip the corners.
6. Place seam Wrong Side up, using the tip of the iron, press seam open.
7. Turn facing to inside of garment, allowing seam line to roll inside slightly, now top stitch at a distance of 1/4".

Steps of Construction

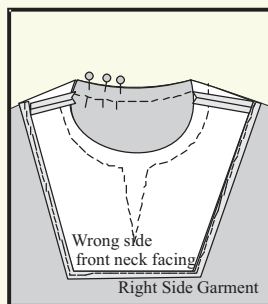

Step -4

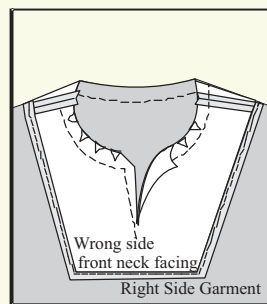

Step -5

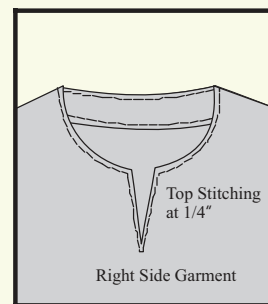

Step -6

Observations

The ready piping should not be more than 1/4" wide and should look neat and straight with no extra twist or pucker.

Viva questions

1. What is true bias and what are its characteristics?
2. What is facing? Where all it is used?

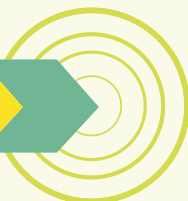

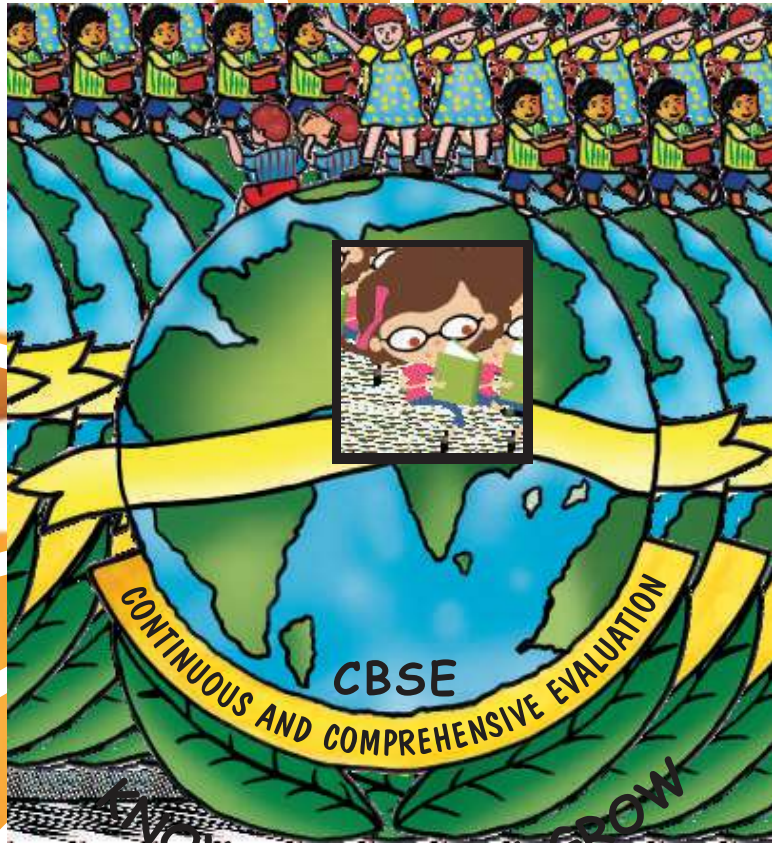

NOW - AS YOU GROW

