

Chapter 3

Laws of Motion

Topic-1 Equilibrium of Forces and Dynamics of Uniform Circular Motion

LIST OF TOPICS :

Topic-1 : Equilibrium of Forces and Dynamics of Uniform Circular Motion

Topic-2 : Frictional Forces

JEE (Main) Previous Year Questions

Multiple Choice Questions

1. A child stands on the edge of the cliff 10 m above the ground and throws a stone horizontally with an initial speed of 5 m s^{-1} . Neglecting the air resistance, the speed with which the stone hits the ground will be $__ \text{ m s}^{-1}$ (given, $g = 10 \text{ m s}^{-2}$).

(1) 15 (2) 20 (3) 30 (4) 25

[JEE (Main) – 1st Feb. 2023 - Shift-1]

2. A stone of mass 1 kg is tied to end of a massless string of length 1 m. If the breaking tension of the string is 400 N, then maximum linear velocity, the stone can have without breaking the string, while rotating in horizontal plane, is:

(1) 40 m s^{-1} (2) 400 m s^{-1}
(3) 20 m s^{-1} (4) 10 m s^{-1}

[JEE (Main) – 31st Jan. 2023 - Shift-2]

3. 100 balls each of mass m moving with speed v simultaneously strike a wall normally and reflected back with same speed, in time t second. The total force exerted by the balls on the wall is:

(1) $\frac{100mv}{t}$ (2) $200mvt$ (3) $\frac{mv}{100t}$ (4) $\frac{200mv}{t}$

[JEE (Main) – 31st Jan. 2023 - Shift-1]

4. A machine gun of mass 10 kg fires 20 g bullets at the rate of 180 bullets per minute with a speed of 100 m s^{-1} each. The recoil velocity of the gun is:

(1) 1.5 m s^{-1} (2) 0.6 m s^{-1}
(3) 2.5 m s^{-1} (4) 0.02 m s^{-1}

[JEE (Main) – 30th Jan. 2023 - Shift-2]

5. The figure represents the momentum time ($p-t$) curve for a particle moving along an axis under the influence of the force. Identify the regions on the graph where the magnitude of the force is maximum and minimum respectively?

If $(t_3 - t_2) < t_1$

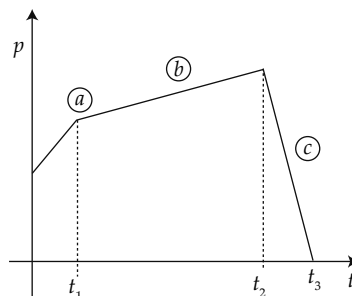

(1) c and b (2) b and c (3) a and b (4) c and a

[JEE (Main) – 30th Jan. 2023 - Shift-1]

6. A force acts for 20 s on a body of mass 20 kg, starting from rest, after which the force ceases and then body describes 50 m in the next 10 s. The value of force will be:

(1) 40 N (2) 5 N (3) 20 N (4) 10 N

[JEE (Main) – 29th Jan. 2023 - Shift-2]

7. A car is moving with a constant speed of 20 m/s in a circular horizontal track of radius 40 m. A

bob is suspended from the roof of the car by a massless string. The angle made by the string with the vertical will be: (Take $g = 10 \text{ m/s}^2$)

- (1) $\frac{\pi}{3}$ (2) $\frac{\pi}{2}$ (3) $\frac{\pi}{4}$ (4) $\frac{\pi}{6}$

[JEE (Main) – 25th Jan. 2023 - Shift-1]

8. An object of mass 8 kg hanging from one end of a uniform rod CD of mass 2 kg and length 1 m pivoted at its end C on a vertical wall as shown in figure. It is supported by a cable AB such that the system is in equilibrium. The tension in the cable is: (Take $g = 10 \text{ m/s}^2$)

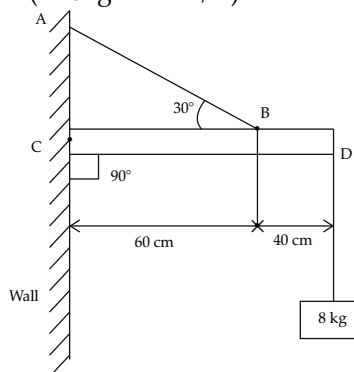

- (1) 90 N (2) 30 N (3) 300 N (4) 240 N

[JEE (Main) – 25th Jan. 2023 - Shift-1]

9. The position vector of a particle related to time t is given by, $\vec{r} = (10t\hat{i} + 15t^2\hat{j} + 7\hat{k}) \text{ m}$

The direction of net force experienced by the particle is:

- (1) Positive z-axis (2) In x - y plane
(3) Positive y -axis (4) Positive x -axis

[JEE (Main) – 15th April 2023 - Shift-1]

10. A bullet of 10 g leaves the barrel of gun with a velocity of 600 m s^{-1} . If the barrel of gun is 50 cm long and mass of gun is 3 kg, then value of impulse supplied to the gun will be:

- (1) 12 N s (2) 6 N s (3) 3 N s (4) 36 N s

[JEE (Main) – 13th April 2023 - Shift-1]

11. Three forces $F_1 = 10 \text{ N}$, $F_2 = 8 \text{ N}$, $F_3 = 6 \text{ N}$ are acting on a particle of mass 5 kg. The forces F_2 and F_3 are applied perpendicularly so that particle remains at rest. If the force F_1 is removed, then the acceleration of the particle is :

- (1) 4.8 m s^{-2} (2) 0.5 m s^{-2}
(3) 7 m s^{-2} (4) 2 m s^{-2}

[JEE (Main) – 12th April 2023 - Shift-1]

12. An average force of 125 N is applied on a machine gun firing bullets each of mass 10 g at the speed of 250 m s^{-1} to keep it in position. The number of bullets fired per second by the machine gun is:

- (1) 25 (2) 5 (3) 100 (4) 50

[JEE (Main) – 11th April 2023 - Shift-1]

13. A child of mass 5 kg is going round a merry-go-round that makes 1 rotation in 3.14 s. The radius of the merry-go-round is 2 m. The centrifugal force on the child will be:

- (1) 40 N (2) 100 N (3) 80 N (4) 50 N

[JEE (Main) – 6th April 2023 - Shift-2]

14. A stone of mass m , tied to a string is being whirled in a vertical circle with a uniform speed. The tension in the string is:

- (1) the same throughout the motion.
(2) minimum at the highest position of the circular path.
(3) minimum at the lowest position of the circular path.
(4) minimum when the rope is in the horizontal position. [JEE (Main) – 24th June 2022 - Shift-2]

15. For a particle in uniform circular motion. The acceleration \vec{a} at any point $P(R, \theta)$ on the circular path of radius R is (where θ is measured from the positive x -axis and v is uniform speed):

- (1) $-\frac{v^2}{R} \sin \theta \hat{i} + \frac{v^2}{R} \cos \theta \hat{j}$
(2) $-\frac{v^2}{R} \cos \theta \hat{i} + \frac{v^2}{R} \sin \theta \hat{j}$
(3) $-\frac{v^2}{R} \cos \theta \hat{i} - \frac{v^2}{R} \sin \theta \hat{j}$ (4) $-\frac{v^2}{R} \hat{i} + \frac{v^2}{R} \hat{j}$

[JEE (Main) – 25th June 2022 - Shift-2]

16. A disc with a flat small bottom beaker placed on it at a distance R from its center is revolving about an axis passing through the center and perpendicular to its plane with an angular velocity ω . The coefficient of static friction between the bottom of the beaker and the surface of the disc is μ . The beaker will revolve with the disc if:

- (1) $R \leq \frac{\mu g}{2\omega^2}$ (2) $R \leq \frac{\mu g}{\omega^2}$

- (3) $R \geq \frac{\mu g}{2\omega^2}$ (4) $R \geq \frac{\mu g}{\omega^2}$

[JEE (Main) – 25th June 2022 - Shift-2]

17. In the arrangement shown in the figure a_1 , a_2 , a_3 and a_4 are the acceleration of masses m_1 , m_2 , m_3 and m_4 respectively. Which of the following relation is true for this arrangement?

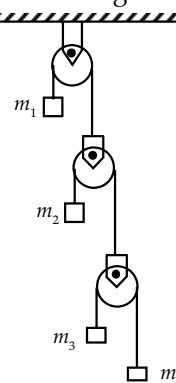

- (1) $4a_1 + 2a_2 + a_3 + a_4 = 0$
- (2) $a_1 + 4a_2 + 3a_3 + a_4 = 0$
- (3) $a_1 + 4a_2 + 3a_3 + 2a_4 = 0$
- (4) $2a_1 + 2a_2 + 3a_3 + a_4 = 0$

[JEE (Main) – 26th June 2022 - Shift-2]

18. A ball is released from rest from point P of a smooth semi-spherical vessel as shown in figure. The ratio of the centripetal force and normal reaction on the ball at point Q is A while angular position of point Q is α with respect to point P. Which of the following graphs represents the correct relation between A and α when ball goes from Q to R?

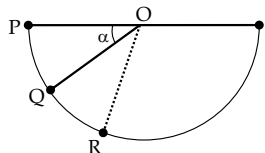

- (1)
- (2)
- (3)
- (4)

[JEE (Main) – 26th June 2022 - Shift-1]

19. A person is standing in an elevator. In which situation, he experiences weight loss?
- (1) When the elevator moves upward with constant acceleration.
 - (2) When the elevator moves downward with constant acceleration.
 - (3) When the elevator moves upward with uniform velocity.
 - (4) When the elevator moves downward with uniform velocity.

[JEE (Main) – 26th June 2022 - Shift-1]

20. Three identical charged balls each of charge 2 C are suspended from a common point P by silk threads of 2 m each (as shown in figure). They form an equilateral triangle of side 1 m. The ratio of net force on a charged ball to the force between any two charged balls will be:

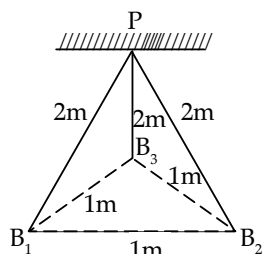

- (1) 1 : 1
- (2) 1 : 4
- (3) $\sqrt{3} : 2$
- (4) $\sqrt{3} : 1$

[JEE (Main) – 27th June 2022 - Shift-2]

21. What percentage of kinetic energy of a moving particle is transferred to a stationary particle when it strikes the stationary particle of 5 times its mass?

(Assume the collision to be head-on elastic collision)

- (1) 50.0%
- (2) 66.6%
- (3) 55.6%
- (4) 33.3%

[JEE (Main) – 27th June 2022 - Shift-1]

22. A block of mass 2 kg moving on a horizontal surface with speed of 4 ms^{-1} enters a rough surface ranging from $x = 0.5 \text{ m}$ to $x = 1.5 \text{ m}$. The retarding force in this range of rough surface is related to distance by $F = -kx$ where $k = 12 \text{ Nm}^{-1}$. The speed of the block as it just crosses the rough surface will be:

- (1) zero
- (2) 1.5 ms^{-1}
- (3) 2.0 ms^{-1}
- (4) 2.5 ms^{-1}

[JEE (Main) – 28th June 2022 - Shift-2]

23. A ball is projected from the ground with a speed 15 ms^{-1} at an angle θ with horizontal so that its range and maximum height are equal, then 'tan θ ' will be equal to:

- (1) $\frac{1}{4}$
- (2) $\frac{1}{2}$
- (3) 2
- (4) 4

[JEE (Main) – 25th July 2022 - Shift-2]

24. For a free body diagram shown in the figure, the four forces are applied in the 'x' and 'y' directions. What additional force must be applied and at what angle with positive x-axis so that the net acceleration of body is zero?

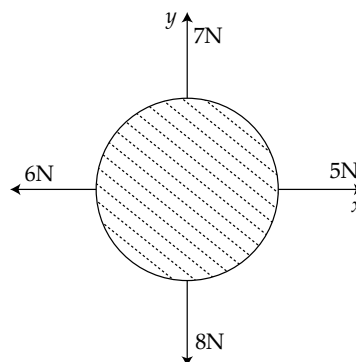

- (1) $\sqrt{2} \text{ N}, 45^\circ$
- (2) $\sqrt{2} \text{ N}, 135^\circ$
- (3) $\frac{2}{\sqrt{3}} \text{ N}, 30^\circ$
- (4) $2 \text{ N}, 45^\circ$

[JEE (Main) – 25th July 2022 - Shift-2]

25. Two masses M_1 and M_2 are tied together at the two ends of a light inextensible string that passes over a frictionless pulley. When the mass M_2 is twice that of M_1 , the acceleration of the system is a_1 . When the mass M_2 is thrice that of M_1 , the acceleration of the system is a_2 . The ratio $\frac{a_1}{a_2}$ will be:

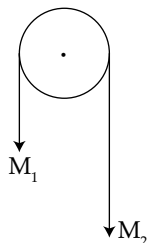

- (1) $\frac{1}{3}$ (2) $\frac{2}{3}$ (3) $\frac{3}{2}$ (4) $\frac{1}{2}$

[JEE (Main) – 26th July 2022 - Shift-2]

26. A ball of mass 0.15 kg hits the wall with its initial speed of 12 ms^{-1} and bounces back without changing its initial speed. If the force applied by the wall on the ball during the contact is 100 N, calculate the time duration of contact of ball with the wall.

- (1) 0.018 s (2) 0.036 s (3) 0.009 s (4) 0.072 s

[JEE (Main) – 26th July 2022 - Shift-2]

27. Two projectiles thrown at 30° and 45° with the horizontal respectively, reach the maximum height in same time. The ratio of their initial velocities is :

- (1) $1 : \sqrt{2}$ (2) $2 : 1$ (3) $\sqrt{2} : 1$ (4) $1 : 2$

[JEE (Main) – 26th July 2022 - Shift-1]

28. A monkey of mass 50 kg climbs on a rope which can withstand the tension (T) of 350 N. If monkey initially climbs down with an acceleration of 4 m/s^2 and then climbs up with an acceleration of 5 m/s^2 . Choose the correct option ($g = 10 \text{ m/s}^2$).

- (1) $T = 700 \text{ N}$ while climbing upward
 (2) $T = 350 \text{ N}$ while going downward
 (3) Rope will break while climbing upward
 (4) Rope will break while going downward

[JEE (Main) – 26th July 2022 - Shift-1]

29. Three masses $M = 100 \text{ kg}$, $m_1 = 10 \text{ kg}$ and $m_2 = 20 \text{ kg}$ are arranged in system as shown in figure. All the surfaces are frictionless and strings are inextensible and weightless. The pulleys are also weightless and frictionless. A force F is applied on the system so that the mass m_2 moves upward with an acceleration 2 ms^{-2} . The value of F is : (Take $g = 10 \text{ ms}^{-2}$)

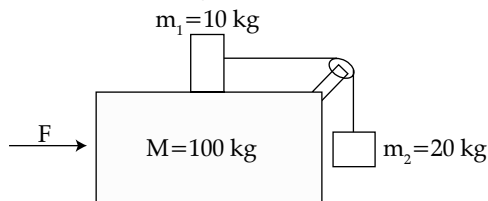

- (1) 3360 N (2) 3380 N (3) 3120 N (4) 3240 N

[JEE (Main) – 26th July 2022 - Shift-1]

30. A body of mass 10 kg is projected at an angle of 45° with the horizontal. The trajectory of the body is observed to pass through a point (20,10). If T is the time of flight, then its momentum vector, at time $t = \frac{T}{\sqrt{2}}$, is _____. [Take $g = 10 \text{ m/s}^2$]

- (1) $100\hat{i} + (100\sqrt{2} - 200)\hat{j}$
 (2) $100\sqrt{2}\hat{i} + (100 - 200\sqrt{2})\hat{j}$
 (3) $100\sqrt{2}\hat{i} + (100 - 200\sqrt{2})\hat{j}$
 (4) $100\sqrt{2}\hat{i} + (100\sqrt{2} - 200)\hat{j}$

[JEE (Main) – 27th July 2022 - Shift-2]

31. A bullet is shot vertically downwards with an initial velocity of 100 m/s from a certain height. Within 10s, the bullet reaches the ground and instantaneously comes to rest due to the perfectly inelastic collision. The velocity–time curve for total time $t = 20 \text{ s}$ will be : (Take $g = 10 \text{ m/s}^2$).

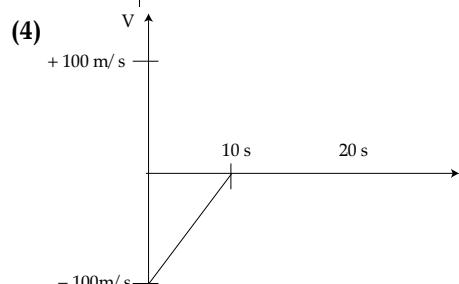
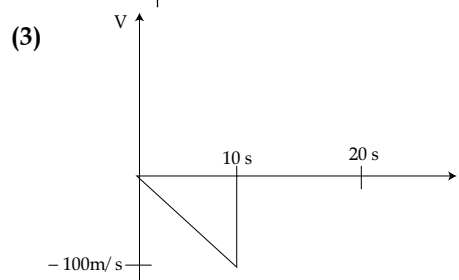
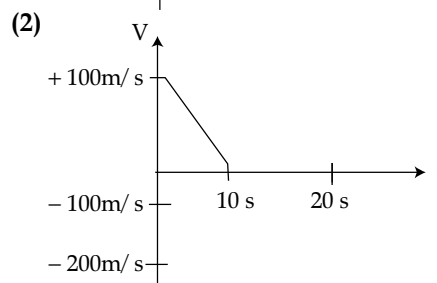
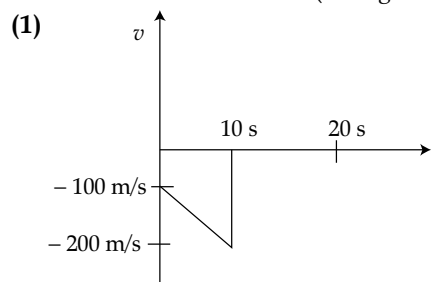

[JEE (Main) – 27th July 2022 - Shift-1]

32. At time $t = 0$ a particle starts travelling from a height 7 cm in a plane keeping z coordinate constant. At any instant of time its position along the \hat{x} and \hat{y} directions are defined as $3t$ and $5t^3$ respectively. At $t = 1$ s acceleration of the particle will be:
- (1) $-30\hat{y}$ (2) $30\hat{y}$
 (3) $3\hat{x} + 15\hat{y}$ (4) $3\hat{x} + 15\hat{y} + 7\hat{z}$
[JEE (Main) – 28th July 2022 - Shift-2]
33. A balloon has mass 10 g in air. The air escapes from the balloon at a uniform rate with velocity 4.5 cm/s. If the balloon shrinks in 5 s completely. Then, the average force acting on that balloon will be (in dyne).
- (1) 3 (2) 9 (3) 12 (4) 18
[JEE (Main) – 28th July 2022 - Shift-1]
34. In two different experiments, an objects of mass 5 kg moving with a speed of 25 ms^{-1} hits two different walls and comes to rest within (i) 3 s, (ii) 5 s, respectively. Choose the correct option out of the following:
- (1) Impulse and average force acting on the object will be same for both the cases.
 (2) Impulse will be same for both the cases but the average force will be different.
 (3) Average force will be same for both the cases but the impulse will be different.
 (4) Average force and impulse will be different for both the cases.
[JEE (Main) – 28th July 2022 - Shift-1]
35. A NCC parade is going at a uniform speed of 9 km/h under a mango tree on which a monkey is sitting at height of 19.6 m. At any particular instant, the monkey drops a mango. A cadet will receive the mango whose distance from the tree at time of drop is :
- (Given $g = 9.8 \text{ m/s}^2$)
 (1) 5 m (2) 10 m (3) 19.8 m (4) 24.5 m
[JEE (Main) – 28th July 2022 - Shift-1]
36. A ball is thrown up vertically with a certain velocity so that, it reaches a maximum height h . Find the ratio of the times in which it is at height $\frac{h}{3}$ while going up and coming down respectively.
- (1) $\frac{\sqrt{2}-1}{\sqrt{2}+1}$ (2) $\frac{\sqrt{3}-\sqrt{2}}{\sqrt{3}+\sqrt{2}}$ (3) $\frac{\sqrt{3}-1}{\sqrt{3}+1}$ (4) $\frac{1}{3}$
[JEE (Main) – 29th July 2022 - Shift-1]
37. The vertical component of the earth's magnetic field is $6 \times 10^{-5} \text{ T}$ at any place where the angle of dip is 37° . The earth's resultant magnetic field at that place will be: (Given $\tan 37^\circ = \frac{3}{4}$)
- (1) $8 \times 10^{-5} \text{ T}$ (2) $6 \times 10^{-5} \text{ T}$
 (3) $5 \times 10^{-4} \text{ T}$ (4) $1 \times 10^{-4} \text{ T}$
[JEE (Main) – 29th July 2022 - Shift-2]
38. If $t = \sqrt{x} + 4$, then $\left(\frac{dx}{dt}\right)_{t=4}$ is :
- (1) 4 (2) 0 (3) 8 (4) 16
[JEE (Main) – 29th July 2022 - Shift-1]
39. Two stars of masses m and $2m$ at a distance d rotate about their common centre of mass in free space. The period of revolution is:
- (1) $2\pi\sqrt{\frac{d^3}{3Gm}}$ (2) $\frac{1}{2\pi}\sqrt{\frac{3Gm}{d^3}}$
 (3) $\frac{1}{2\pi}\sqrt{\frac{d^3}{3Gm}}$ (4) $2\pi\sqrt{\frac{3Gm}{d^3}}$
[JEE (Main) – 24th Feb. 2021 - Shift-1]
40. A stone is dropped from the top of a building. When it crosses a point 5 m below the top, another stone starts to fall from a point 25 m below the top. Both stones reach the bottom of building simultaneously. The height of the building is:
- (1) 45 m (2) 35 m (3) 25 m (4) 50 m
[JEE (Main) – 25th Feb. 2021 - Shift-2]
41. Given below are two statements : one is labelled as Assertion A and the other is labelled as Reason R.
- Assertion (A):** Body 'P' having mass M moving with speed ' u ' has head-on collision elastically with another body 'Q' having mass ' m ' initially at rest. If $m \ll M$, body 'Q' will have a maximum speed equal to ' $2u$ ' after collision.
- Reason (R):** During elastic collision, the momentum and kinetic energy are both conserved.
- In the light of the above statements, choose the most appropriate answer from the options given below:
- (1) A is correct but R is not correct.
 (2) Both A and R are correct but R is NOT the correct explanation of A.
 (3) A is not correct but R is correct.
 (4) Both A and R are correct and R is the correct explanation of A.
[JEE (Main) – 26th Feb. 2021 - Shift-1]

42. Two masses A and B, each of mass M are fixed together by a massless springs. A force acts on the mass B as shown in figure. If the mass A starts moving away from mass B with acceleration ' a ', than the acceleration of mass B will be:

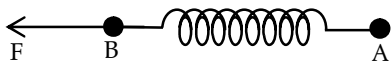

- (1) $\frac{F + Ma}{M}$ (2) $\frac{F - Ma}{M}$ (3) $\frac{Ma - F}{M}$ (4) $\frac{MF}{F + Ma}$

[JEE (Main) – 26th Feb. 2021 - Shift-2]

43. A block of 200 g mass moves with a uniform speed in a horizontal circular groove, with vertical side walls of radius 20 cm. If the block takes 40 s to complete one round, the normal force by the side walls of the groove is:

- (1) 6.28×10^{-3} N (2) 0.0314 N
(3) 9.859×10^{-2} N (4) 9.859×10^{-4} N

[JEE (Main) – 16th March 2021 - Shift-1]

44. A car accelerates from rest at a constant rate α for some time after which it decelerates at a constant rate β to come to rest. If the total time elapsed is t seconds, the total distance travelled is:

- (1) $\frac{\alpha\beta}{2(\alpha + \beta)} t^2$ (2) $\frac{\alpha\beta}{4(\alpha + \beta)} t^2$
(3) $\frac{4\alpha\beta}{(\alpha + \beta)} t^2$ (4) $\frac{2\alpha\beta}{(\alpha + \beta)} t^2$

[JEE (Main) – 17th March 2021 - Shift-1]

45. The position, velocity and acceleration of a particle moving with a constant acceleration can be represented by:

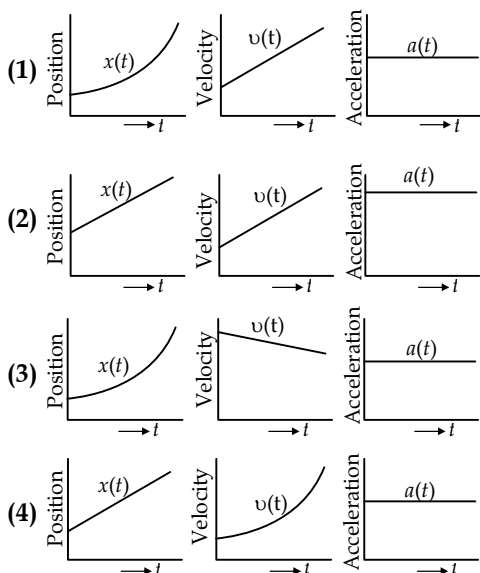

[JEE (Main) – 18th March 2021 - Shift-1]

46. The velocity – displacement graph of a particle is shown in the figure.

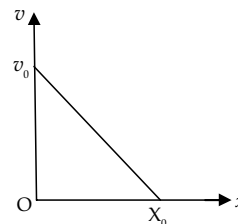

The acceleration – displacement graph of the same particle is represented by :

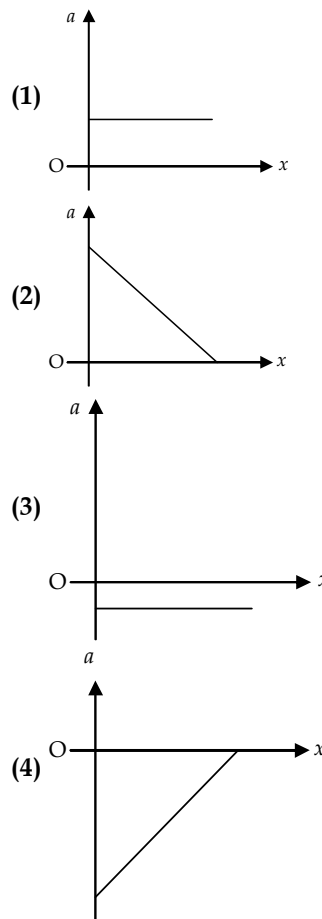

[JEE (Main) – 18th March 2021 - Shift-2]

47. A steel block of 10 kg rests on a horizontal floor as shown. When three iron cylinders are placed on it as shown, the block and cylinders go down with an acceleration 0.2 m/s^2 . The normal reaction R' by the floor if mass of the iron cylinders are equal and of 20 kg each, is _____ [take $g = 10 \text{ m/s}^2$ and $\mu_s = 0.2$]

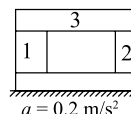

- (1) 714 (2) 716 (3) 684 (4) 686

[JEE (Main) – 20th July 2021 - Shift-1]

48. The normal reaction 'N' for a vehicle of 800 kg mass, negotiating a turn on a 30° banked road at maximum possible speed without skidding is _____ × 10³ kg m/s².

[Given cos30° = 0.87, μ_s = 0.2]

- (1) 12.4 (2) 7.2 (3) 6.96 (4) 10.2

[JEE (Main) – 20th July 2021 - Shift-1]

49. A bullet of '4 g' mass is fired from a gun of mass 4 kg. If the bullet moves with the muzzle speed of 50 ms⁻¹, the impulse imparted to the gun and velocity of recoil of gun are:

- (1) 0.4 kg ms⁻¹, 0.1 ms⁻¹
 (2) 0.2 kg ms⁻¹, 0.1 ms⁻¹
 (3) 0.2 kg ms⁻¹, 0.05 ms⁻¹
 (4) 0.4 kg ms⁻¹, 0.05 ms⁻¹

[JEE (Main) – 22nd July 2021 - Shift-2]

50. Two billiard balls of equal mass 30 g strike a rigid wall with same speed of 108 kmph (as shown) but at different angles. If the balls get reflected with the same speed, then the ratio of the magnitude of impulses imparted to ball 'a' and ball 'b' by the wall along 'X' direction is:

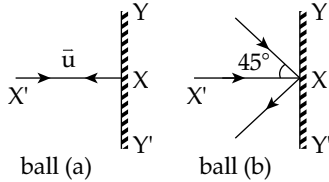

- (1) 1 : 1 (2) √2 : 1 (3) 1 : √2 (4) 2 : 1

[JEE (Main) – 25th July 2021 - Shift-1]

51. A force $\vec{F} = (40\hat{i} + 10\hat{j})$ N acts on a body of mass 5 kg. If the body starts from rest, its position vector \vec{r} at time $t = 10$ s, will be:

- (1) $(100\hat{i} + 400\hat{j})$ m (2) $(400\hat{i} + 100\hat{j})$ m
 (3) $(100\hat{i} + 100\hat{j})$ m (4) $(400\hat{i} + 400\hat{j})$ m

[JEE (Main) – 25th July 2021 - Shift-2]

52. Three objects A, B and C are kept in a straight line on a frictionless horizontal surface. The masses of A, B and C are m , $2m$ and $2m$ respectively. A moves towards B with a speed of 9 m/s and makes an elastic collision with it. Thereafter B makes a completely inelastic collision with C. All motions occur along same straight line. The final speed of C is:

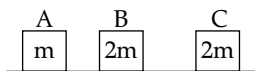

- (1) 3 m/s (2) 6 m/s (3) 9 m/s (4) 4 m/s

[JEE (Main) – 27th July 2021 - Shift-1]

53. Figure A and B show two long straight wires of circular cross-section (a and b with $a < b$), carrying current I which is uniformly distributed across the cross-section. The magnitude of magnetic field B varies with radius r and can be represented as :

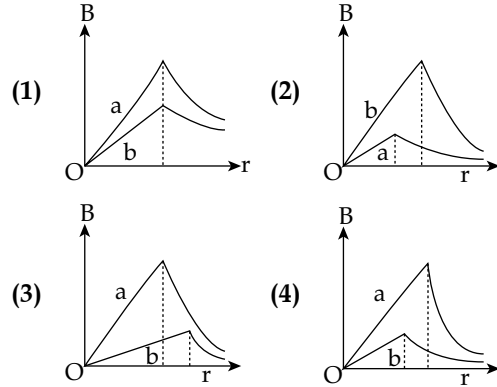
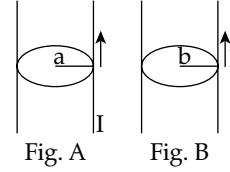

[JEE (Main) – 27th July 2021 - Shift-2]

54. The initial mass of a rocket is 1000 kg. Calculate at what rate the fuel should be burnt so that the rocket is given an acceleration of 20 ms⁻². The gases come out at a relative speed of 500 ms⁻¹ with respect to the rocket:

- (1) 60 kg s⁻¹ (2) 10 kg s⁻¹
 (3) 6.0 × 10² kg s⁻¹ (4) 500 kg s⁻¹

[JEE (Main) – 26th Aug. 2021 - Shift-1]

55. Two blocks of masses 3 kg and 5 kg are connected by a metal wire going over a smooth pulley. The breaking stress of the metal is $\frac{24}{\pi} \times 10^2$ Nm⁻².

What is the minimum radius of the wire?
 (take $g = 10$ ms⁻²)

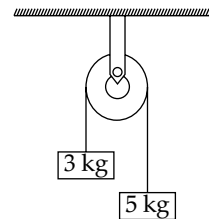

- (1) 125 cm (2) 150 cm (3) 1.25 cm (4) 12.5 cm

[JEE (Main) – 26th Aug. 2021 - Shift-2]

56. A particle of mass m is suspended from a ceiling through a string of length L . The particle moves in a horizontal circle of radius r such that

$r = \frac{L}{\sqrt{2}}$. The speed of particle will be:

- (1) $2\sqrt{rg}$ (2) $\sqrt{2rg}$ (3) \sqrt{rg} (4) $\sqrt{\frac{rg}{2}}$

[JEE (Main) – 26th Aug. 2021 - Shift-2]

57. The boxes of masses 2 kg and 8 kg are connected by a massless string passing over smooth pulleys. Calculate the time taken by box of mass 8 kg to strike the ground starting from rest. (use $g = 10 \text{ m/s}^2$)

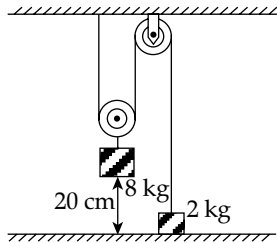

- (1) 0.25 s (2) 0.34 s (3) 0.2 s (4) 0.4 s

[JEE (Main) – 27th Aug. 2021 - Shift-2]

58. A spaceship in space sweeps stationary interplanetary dust. As a result, its mass increases at a rate $\frac{dM(t)}{dt} = bv^2(t)$, where $v(t)$ is its instantaneous velocity. The instantaneous acceleration of the satellite is :

- (1) $-\frac{bv^3}{2M(t)}$ (2) $-bv^3(t)$ (3) $-\frac{2bv^3}{M(t)}$ (4) $-\frac{bv^3}{M(t)}$

[JEE (Main) – 5th Sep. 2020 - Shift-2]

59. A particle is moving along a circular path with a constant speed of 10 ms^{-1} . What is the magnitude of the change in velocity of the particle, when it moves through an angle of 60° around the centre of the circle?

- (1) $10\sqrt{2} \text{ m/s}$ (2) $10\sqrt{3} \text{ m/s}$
 (3) 10 m/s (4) Zero

[JEE (Main) – 11th Jan. 2019 - Shift-1]

60. The road at a circular turn of radius 10 m is banked by an angle of 10° . With what speed should a Vehicle move on the turn So that the Normal contact force is able to provide the necessary centripetal form [$\tan 10^\circ = 0.176$]

- (1) 4.0 m/s (2) 3.8 m/s
 (3) 2.4 m/s (4) 4.2 m/s

61. A car taken a circular, turn of radius 20m at a speed of 54 km/h. What is the least coefficient of friction between tyres and road that can Prevent slide shipping?

- (1) 1.5 (2) 1.2
 (3) 1.15 (4) 41.12

ANSWER – KEY

1. (1) 2. (3) 3. (4) 4. (2)
 5. (1) 6. (2) 7. (3) 8. (3)

- | | | | |
|---------|---------|---------|---------|
| 9. (3) | 10. (2) | 11. (4) | 12. (4) |
| 13. (1) | 14. (2) | 15. (3) | 16. (2) |
| 17. (1) | 18. (3) | 19. (2) | 20. (4) |
| 21. (3) | 22. (3) | 23. (4) | 24. (1) |
| 25. (2) | 26. (2) | 27. (3) | 28. (3) |
| 29. (1) | 30. (4) | 31. (1) | 32. (2) |
| 33. (2) | 34. (2) | 35. (1) | 36. (2) |
| 37. (4) | 38. (2) | 39. (1) | 40. (1) |
| 41. (4) | 42. (2) | 43. (4) | 44. (1) |
| 45. (1) | 46. (4) | 47. (4) | 48. (4) |
| 49. (3) | 50. (2) | 51. (2) | 52. (1) |
| 53. (3) | 54. (1) | 55. (4) | 56. (3) |
| 57. (4) | 58. (4) | 59. (3) | 60. (4) |
| 61. (3) | | | |

ANSWERS WITH EXPLANATIONS

1. Option (1) is correct.

Resolving motion of ball in two directions

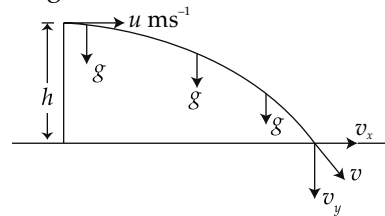

In horizontal direction $a_x = 0$

So $v_x = u_x = \text{constant}$

In vertical direction $a_y = g$

So $v_y = u_y + gt$ But $u_y = 0, v_y = gt$

Also $h = u_y t + \frac{1}{2} a_y t^2 \therefore h = \frac{1}{2} g t^2$

Also $v_y^2 = u_y^2 + 2gh \therefore v_y^2 = 2gh$

at the point of hitting on ground,

$$v = \sqrt{u^2 + 2gh} = \sqrt{25 + 200} = 15 \text{ m s}^{-1}$$

2. Option (3) is correct.

Given, $R = 1 \text{ m}$

$$T_{\max} = 400 \text{ N}$$

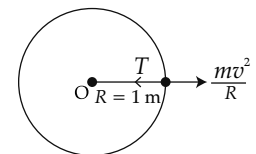

In circular motion

Centripetal force = Centrifugal force

$$\Rightarrow T = \frac{mv^2}{R}$$

$$\Rightarrow 400 = \frac{1 \times v^2}{1}$$

$$\Rightarrow v^2 = 400$$

$$\Rightarrow v = \sqrt{400} = 20 \text{ m s}^{-1}$$

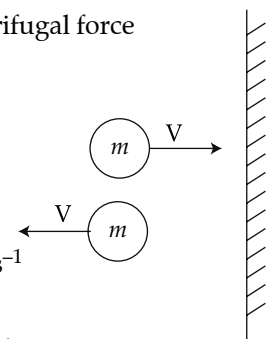

3. Option (4) is correct.

From Newton's second law,

$$F = \frac{dp}{dt}$$

$dp = \text{Change in momentum}$

$p_i = mv =$ Initial momentum of one ball
 $p_f =$ Final momentum of one ball $= mv$
 $dp = p_f - p_i = mv - (-mv) = 2mv$
 Force exerted due to one ball

$$F_{avg} = \frac{dp}{dt} = \frac{2mv}{t}$$

Force exerted by 100 balls

$$F_{avg} = 100 \times \frac{2mv}{t} = \frac{200mv}{t}$$

4. Option (2) is correct.

By conservation by mass principle,

$$\vec{0} = \vec{p}_2 + \vec{p}_1 \Rightarrow \vec{p}_2 = -\vec{p}_1$$

Where \vec{p}_2 and \vec{p}_1 are the momenta of the gun and bullets respectively.

$$|\vec{p}_2| = |\vec{p}_1|$$

$$mv_2 = nmv_1$$

$n =$ no. of bullets fired per second

$$= \frac{180}{60} = 3$$

$$10v_2 = 3 \times \frac{20}{1000} \times 100$$

$$v_2 = 0.6 \text{ m s}^{-1}$$

5. Option (1) is correct.

From Newton's 2nd law of motion $|\vec{F}| = \frac{dp}{dt} =$ slope of $(p-t)$ graph

As can be seen from the given graph, slope of curve c is the maximum and that of curve b is minimum.

6. Option (2) is correct.

After force is removed $a=0$ so object will move with constant velocity, hence

$$v \times 10 = 50$$

$$v = 5 \text{ m s}^{-1}$$

Now by $F \times (\Delta t) = \Delta P$

$$F(20) = 20(5 - 0)$$

$$F = 5 \text{ N}$$

7. Option (3) is correct.

Let the string of the pendulum makes an angle θ with the vertical in the frame of reference of car $\sum \vec{F} = 0$ as Pendulum is in equilibrium.

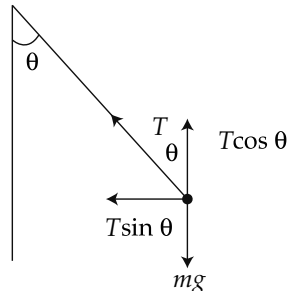

$$T \cos \theta = mg \quad \dots(i)$$

$$T \sin \theta = m \frac{v^2}{R} \text{ (centrifugal force)} \quad \dots(ii)$$

Dividing equation (ii) by (i)

$$\tan \theta = \frac{v^2}{Rg} = \frac{20 \times 26}{40 \times 10} = 1 \Rightarrow \theta = \frac{\pi}{4}$$

8. Option (3) is correct.

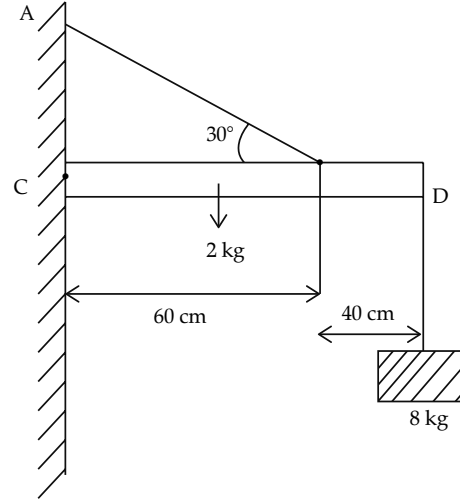

F B D for the above set up is as shown:

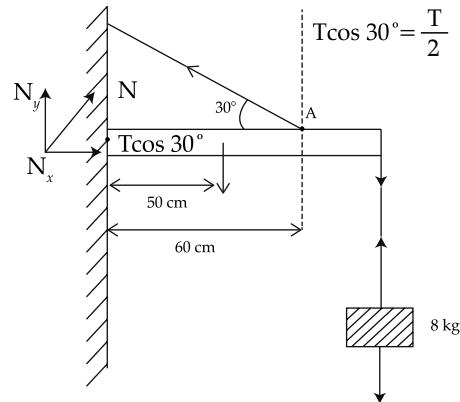

For equilibrium of the rod

$$\sum F_x = 0 \rightarrow N_x = T \cos 30^\circ = T \frac{\sqrt{3}}{2}$$

Where N is the normal reaction exerted on the rod by the wall and $N = \sqrt{N_x^2 + N_y^2}$

$$\text{Also } T_1 = 8g$$

$$\sum F_y = 0 \rightarrow T_1 + 2g = \left(T \sin 30^\circ = \frac{T}{2} \right) + N_y$$

$$8g + 2g = \frac{T}{2} + N_y$$

For rotational equilibrium, net torque about any Point = 0

$$\sum T_s = 0$$

$$2g(0.5) + 8g(1) = (T \sin 30^\circ)(0.6)$$

$$10 + 80 = 0.3T$$

$$T = \frac{90}{0.3} = 300 \text{ N}$$

9. Option (3) is correct.

$$\vec{r} = (10t\hat{i} + 15t^2\hat{j} + 7t\hat{k})m$$

$$\vec{v} = \frac{d\vec{r}}{dt} = 0\hat{i} + 30\hat{j} + 0\hat{k} \Rightarrow \vec{a} = \frac{d\vec{v}}{dt} = 0\hat{i} + 30\hat{j} + 0\hat{k} = 30\hat{j}$$

$$\vec{F} = m\vec{a} = 30m\hat{j}$$

10. Option (2) is correct.

Impulse = change in momentum

$$|\vec{J}| = |\Delta\vec{p}| = mv - 0 = \frac{10}{1000} \times 600 - 0 = 6 \text{ (N s)}$$

11. Option (4) is correct.

Since F_1 is removed, So net force will be in between F_2 and F_3 .

$$\text{Net force, } F = \sqrt{F_1^2 + F_2^2 + 2F_1F_2 \cos 90}$$

$$\Rightarrow F = \sqrt{8^2 + 6^2 + 0} = 10 \text{ N}$$

$$\text{Acceleration, } a = \frac{F}{m} = \frac{10}{5} = 2 \text{ m s}^{-2}$$

12. Option (4) is correct.

Given, Average force, $F = 125 \text{ N}$

Mass of each bullet, $m = 10 \text{ g}$

Velocity of each bullet, $v = 250 \text{ m s}^{-1}$

As per 2nd law of motion, $F = \frac{dp}{dt}$

$$\text{Or } F = \frac{d(nmv)}{dt} = mv \frac{dn}{dt} \Rightarrow \frac{dn}{dt} = \frac{F}{mv}$$

$$\Rightarrow \frac{dn}{dt} = \frac{125}{10 \times 10^{-3} \times 250} = 50$$

13. Option (1) is correct.

Given, $m = 5 \text{ kg}$, $r = 2 \text{ m}$

Time period of rev, $t = 3.14 \text{ s}$ or $\pi \text{ s}$

$$\omega = \frac{\theta}{t} = \frac{2\pi}{\pi} = 2 \text{ rad s}^{-1}$$

$$\Rightarrow F_{\text{centrifugal}} = rm\omega^2$$

$$F = 2 \times 5 \times 2^2 = 40 \text{ N}$$

14. Option (2) is correct.

At the lowest point of the vertical circle

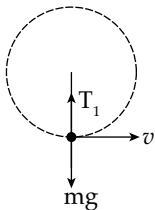

$$T_1 = mg + \frac{mv^2}{R}$$

$$T_1 = mg + \frac{mv^2}{R} \text{ (maximum)}$$

At the highest point of the vertical circle

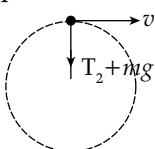

$$T_2 + mg = \frac{mv^2}{R}$$

$$\Rightarrow T_2 = \frac{mv^2}{R} - mg \text{ (Minimum)}$$

15. Option (3) is correct.

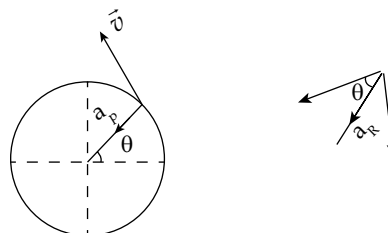

In a uniform circular motion $|\vec{v}| = \text{const} = v$

Centripetal or radial acceleration $a_R = \frac{v^2}{R}$ is directed towards the center of the circular path, as shown.

$$\vec{a}_R = \frac{v^2}{R} \cos \theta (-\hat{i}) + \frac{v^2}{R} \sin \theta (-\hat{j})$$

16. Option (2) is correct.

The beaker will revolve with the disc till

$$f_{\text{max}} \geq m\omega^2 R$$

$$\mu mg \geq m\omega^2 R$$

$$R \leq \frac{\mu g}{\omega^2}$$

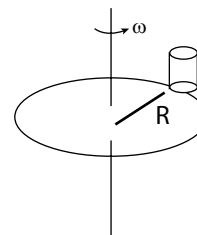

17. Option (1) is correct.

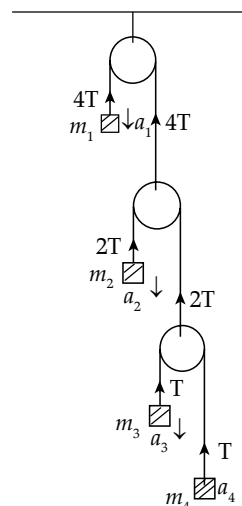

Applying the constraint relation

$$\sum \vec{T} \cdot \vec{a} = 0$$

$$-Ta_4 - Ta_3 - 2Ta_2 - 4Ta_1 = 0$$

$$\Rightarrow 4a_1 + 2a_2 + a_3 + a_4 = 0$$

18. Option (3) is correct.

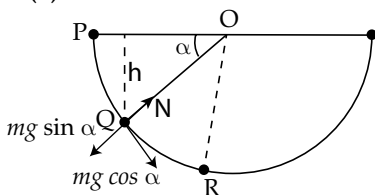

Applying COE from P to Q, $mgh = \frac{1}{2}mv^2$

$$mg(r \sin \alpha) = \frac{1}{2}mv^2$$

$$\frac{mv^2}{r} = 2mg \sin \alpha \quad \dots(i)$$

Also at point Q, $N - mg \sin \alpha = \frac{mv^2}{r}$

$$N = 3mg \sin \alpha \quad \dots(ii)$$

$$\frac{mv^2/r}{N} = \frac{2}{3} = A = \text{const (independent of } \alpha)$$

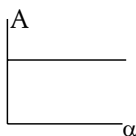

19. Option (2) is correct.

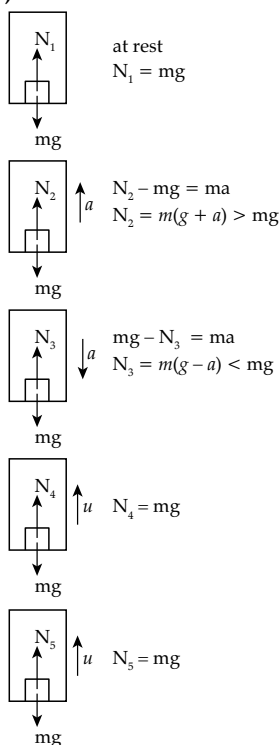

20. Option (4) is correct.

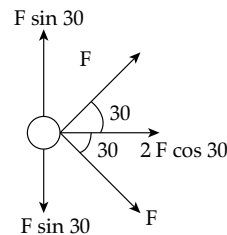
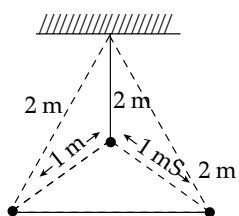

From, vector diagram the net force on any of the charge will be:

$$F_{\text{net}} = 2 F \cos 30$$

Where $F = K \frac{2.2}{1^2} = 4K$

$$F_{\text{net}} = 2 \times 4K \cdot \cos 30 = 4K \cdot \frac{\sqrt{3}}{2} \times 2$$

$$F_{\text{net}} = 4K \sqrt{3}$$

$$\frac{F_{\text{net}}}{F} = \frac{2 \times 2K \sqrt{3}}{4K} = \sqrt{3}$$

21. Option (3) is correct.

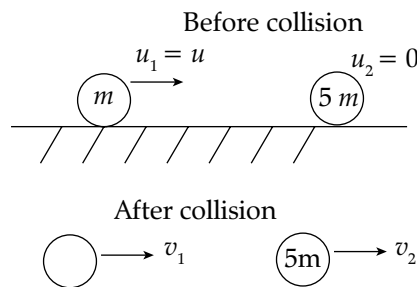

Before collision only block m_1 is moving, when it collides to block of mass of $5m$, which is at rest, their velocities becomes v_1 and v_2 . As collision is elastic so $e = 1$,

Applying conservation of linear momentum

$$m_1 u_1 + m_2 u_2 = m_1 v_1 + m_2 v_2$$

$$m \cdot u + 0 = mv_1 + 5m v_2$$

$$v_1 + 5v_2 = u \quad \dots(i)$$

Now from Newton's equation.

$$v_1 - v_2 = -(u_1 - u_2) = -u \quad \dots(ii)$$

Subtracting eq. (ii) from (i), the value of v_2

$$6v_2 = 2u$$

$$\Rightarrow v_2 = \frac{u}{3}$$

The K.E. gained by block of mass $5m =$ K.E. lost by block of mass m .

$$= \Delta K = \frac{1}{2} \times 5m \cdot \left(\frac{u}{3}\right)^2 = \frac{5}{18} mu^2$$

% change in K.E. of block mass m

$$= \frac{\Delta K}{K} \times 100 = \frac{5/18 mu^2}{1/2 mu^2} \times 100 = 55.6\%$$

22. Option (3) is correct.

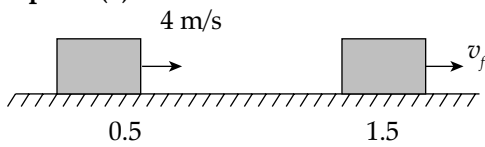

At any x in the range $0.5 \leq x \leq 1.5$

$$F = -12x = mv \frac{dv}{dx}$$

$$\int_4^{v_f} v dv = -6 \int_{0.5}^{1.5} x dx$$

$$\left(\frac{v^2}{2}\right)_4^{v_f} = -3(x^2)_{0.5}^{1.5}$$

$$\frac{v_f^2}{2} - 8 = -3(2.25 - 0.25) = -6$$

$$v_f^2 = 4$$

$$v_f = 2 \text{ m/s}$$

23. Option (4) is correct.

Given $R = H$

$$\frac{2u_x u_y}{g} = \frac{u_y^2}{2g}$$

$$\frac{u_y}{u_x} = 4 = \tan \theta$$

24. Option (1) is correct.

$$\vec{F}_x = (6 - 5)(-\hat{i}) = -\hat{i}$$

$$\vec{F}_y = (8 - 7)(-\hat{j}) = -\hat{j}$$

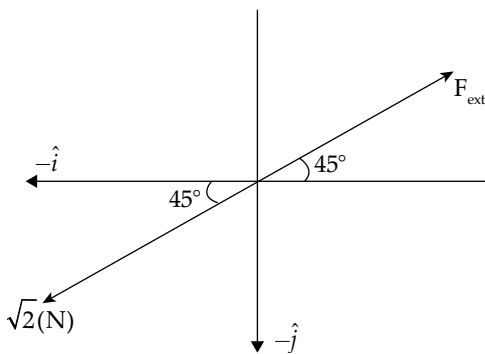

For net acceleration to be zero, $F_{\text{net}} = 0$

$$\therefore F_{\text{ext}} = \sqrt{2} \text{ (N) at } 45^\circ \text{ with } x\text{-axis}$$

25. Option (2) is correct.

Applying newton's law on the given blocks

$$M_2 g - T = M_2 a \dots\dots (i)$$

$$T - M_1 g = M_1 a \dots\dots (ii)$$

On adding above equations

$$(M_2 - M_1)g = (M_2 + M_1)a$$

$$\Rightarrow a = \frac{M_2 - M_1}{M_2 + M_1} g$$

$$\text{When } (M_2 = 2M_1) \Rightarrow a_1 = \frac{2M_1 - M_1}{2M_1 + M_1} g = \frac{1}{3} g$$

$$\text{When } (M_2 = 3M_1) \Rightarrow a_2 = \frac{3M_1 - M_1}{3M_1 + M_1} g = \frac{1}{2} g$$

$$\text{Now, } \frac{a_1}{a_2} = \frac{g/3}{g/2} = \frac{2}{3}$$

$$a_1 : a_2 = 2 : 3$$

26. Option (2) is correct.

Given: $F = 100 \text{ N}$, $m = 0.15 \text{ kg}$,

$u = 12 \text{ ms}^{-1}$, $v = -u = -12 \text{ ms}^{-1}$

According to 2nd law of motion, $F = \frac{dp}{dt}$ or $\frac{\Delta p}{\Delta t}$

$$\Rightarrow F = \frac{m(v - u)}{\Delta t}$$

$$\Rightarrow \Delta t = 0.15 \frac{[12 - (-12)]}{100} = 0.036 \text{ s}$$

27. Option (3) is correct.

Time of flight for both projectiles is same, so

$$\frac{u_1 \sin \theta_1}{g} = \frac{u_2 \sin \theta_2}{g}$$

$$\Rightarrow u_1 \sin 30 = u_2 \sin 45$$

$$\Rightarrow u_1 \times \frac{1}{2} = u_2 \times \frac{1}{\sqrt{2}}$$

$$\Rightarrow \frac{u_1}{u_2} = \frac{\sqrt{2}}{1}$$

28. Option (3) is correct.

Given, $T = 350 \text{ N}$, $m = 50 \text{ kg}$

When monkey is moving downwards

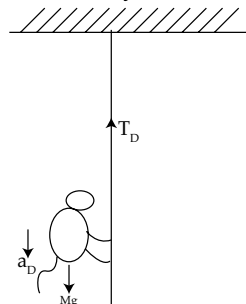

$$T_D - mg = ma_D$$

$$50 \times 10 - T_D = 50 \times 4$$

$$T_D = 500 - 200 = 300 \text{ N}$$

When monkey is moving upwards

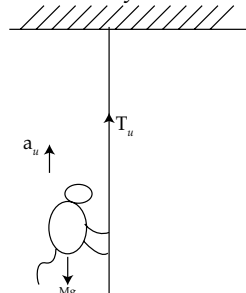

$$T_u - mg = ma_u$$

$$T_u - 50 \times 10 = 50 \times 5$$

$$T_u = 500 + 250 = 750 \text{ N}$$

$T_u > T$, Hence rope will break.

29. Option (1) is correct.

Let acceleration on 100 kg and small blocks are a and a_1 respectively
From FBD of 20 kg block :

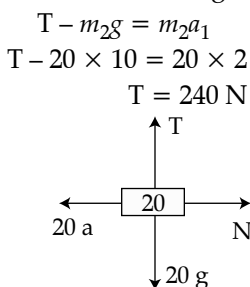

From FBD of 10 kg block :

$$10a - T = m_1 a_1$$

$$10a - 240 = 10 \times 2$$

$$10a = 260$$

$$a = 26 \text{ ms}^{-2}$$

From FBD of 100 kg block

$$F - T - N_{20} = Ma$$

$$F - 240 - 20 \times 26 = 100 \times 26$$

$$F = 3360 \text{ N}$$

$$F - T - N = Ma$$

30. Option (4) is correct.

The equation of trajectory is given by

$$y = x \tan \alpha - \frac{1}{2} \frac{gx^2}{u^2 \cos^2 \alpha}$$

It passed through (20, 10) and $\alpha = 45^\circ$

$$10 = 20 - \frac{5(20)^2}{u^2 \left(\frac{1}{2}\right)}$$

$$-10 = \frac{-10(400)}{u^2}$$

$$u = 20 \text{ m/s}$$

$$T = \frac{2u \sin \alpha}{g} = \frac{2(20)}{10\sqrt{2}} = 2\sqrt{2} \text{ s}$$

$$t = \frac{T}{\sqrt{2}} = 2 \text{ s}$$

$$\vec{v}(t) = v_x \hat{i} + v_y \hat{j}$$

$$= u_x \hat{i} + (u_y - gt) \hat{j}$$

$$= (u \cos \alpha) \hat{i} + (u \sin \alpha - gt) \hat{j}$$

$$= \frac{20}{\sqrt{2}} \hat{i} + \left(\frac{20}{\sqrt{2}} - 20 \right) \hat{j}$$

$$= 10\sqrt{2} \hat{i} + (10\sqrt{2} - 20) \hat{j}$$

$$\vec{p} = m\vec{v} = 10\vec{v} = 100\sqrt{2} \hat{i} + (100\sqrt{2} - 200) \hat{j}$$

31. Option (1) is correct.

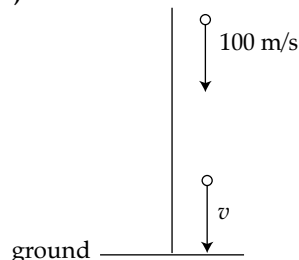

Let v be the velocity of bullet on striking the ground.

Applying $v = u + at$

$$v = -100 + (-10)(10)$$

$$= -200 \text{ m/s}$$

It means velocity is increasing in negative direction also. After striking, it comes instantaneously at rest. Hence, a vertical line on graph will come.

32. Option (2) is correct.

Position of particle at any instant t is,
 $p = x\hat{i} + y\hat{j} + z\hat{k}$.

$$\Rightarrow p = 3t\hat{i} + 5t^3\hat{j} + 7\hat{k}$$

$$\Rightarrow v = \frac{dp}{dt} = 3\hat{i} + 15t^2\hat{j}$$

$$\Rightarrow a = \frac{dv}{dt} = 30t\hat{j}$$

$$\text{At } t = 1 \text{ s, } a = 30 \times 1 = 30 \hat{j}$$

33. Option (2) is correct.

Given, $t = 5 \text{ s}$, $v = 4.5 \frac{\text{cm}}{\text{s}}$, $m = 10 \text{ g}$

$$F_{\text{avg}} = \frac{d(mv)}{dt} = \frac{10}{5} \times 4.5 = 9 \frac{\text{gcm}}{\text{s}^2} = 9 \text{ dyne}$$

34. Option (2) is correct.

Impulse, $I = \text{change in momentum}$

Since mass of object and change in velocity is same, so $\Delta p_1 = \Delta p_2$.

$$F = \text{Rate of change of momentum} = \frac{\Delta p}{\Delta t}$$

Since Δp is same, so Force $F \propto \frac{1}{\Delta t}$

$$\therefore t_1 < t_2 \quad \therefore F_2 < F_1$$

35. Option (1) is correct.

For mango, height of mango tree, $h = 19.6 \text{ m}$

Initial speed of mango, $u = 0 \text{ m/s}$

From 2nd equation of motion, $h = ut + \frac{1}{2}at^2$

$$19.6 = 0 \times t + \frac{1}{2} \times 9.8 \times t^2$$

$$t^2 = 4$$

Time taken by mango to reach ground, $t = 2$ second

Speed of cadets, $v = 9 \text{ km/h} = 2.5 \text{ m/s}$

Distance covered by cadets in 2 second, $d = vt$

$$d = 2.5 \times 2 = 5 \text{ m}$$

Hence, cadet standing at a distance of 5 m from tree will receive mango.

36. Option (2) is correct.

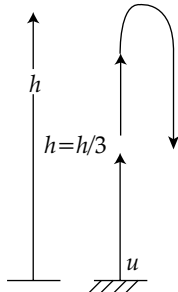

Let in time t_1 the ball reaches to height $h/3$ and

in time t_2 it again reaches to height $h/3$.

It is initially thrown with velocity u , reaches to height ' h '

$$h = \frac{u^2}{2g} \Rightarrow u = \sqrt{2gh}$$

Now from 2nd equation of motion, $s = ut + \frac{1}{2}gt^2$

$$\frac{h}{3} = \sqrt{2gh}t + \frac{1}{2}(-g)t^2$$

$$g \frac{t^2}{2} - \sqrt{2gh}t + \frac{h}{3} = 0$$

t_1 and t_2 will be roots of above equations,

$$\frac{t_2}{t_1} = \frac{\sqrt{2gh} + \sqrt{2gh - 4 \times \frac{g}{2} \times \frac{h}{3}}}{\sqrt{2gh} - \sqrt{2gh - 4 \times \frac{g}{2} \times \frac{h}{3}}}$$

$$\frac{t_2}{t_1} = \frac{\sqrt{2gh} + \sqrt{\frac{4gh}{3}}}{\sqrt{2gh} - \sqrt{\frac{4gh}{3}}} = \frac{\sqrt{3} + \sqrt{2}}{\sqrt{3} - \sqrt{2}}$$

37. Option (4) is correct.



Vertical component of earth's magnetic field.

$$B_V = 6 \times 10^{-5} \text{ T}$$

Angle of dip $S = 37^\circ$

$$B_V = B \sin S$$

$$6 \times 10^{-5} = B \times \frac{3}{5}$$

$$B = 10^{-4} \text{ T}$$

38. Option (2) is correct.

$$\text{Given, } t = \sqrt{x} + 4,$$

Squaring on both sides, we get

$$x = (t - 4)^2 = t^2 - 8t + 16$$

$$\frac{dx}{dt} = 2t - 8 = 0$$

$$\text{at } t = 4$$

$$\frac{dx}{dt} = 8 - 8 = 0$$

39. Option (1) is correct.

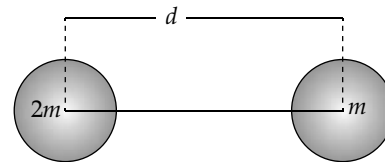

$$X_{\text{com}} = \frac{2m \times 0 + m \cdot d}{2m + m} = \frac{d}{3}$$

Now, applying force balance equation

$$\leftarrow F_c \quad \rightarrow F_g$$

$$F_c = F_g$$

$$\Rightarrow \frac{(2m)v^2}{X_{\text{com}}} = \frac{G(2m) \cdot m}{d^2}$$

$$\Rightarrow \frac{2m \left(\omega \frac{d}{3} \right)^2}{\left(\frac{d}{3} \right)} = \frac{2Gm^2}{d^2}$$

$$\Rightarrow \omega^2 = \frac{2Gm^2}{2m \frac{d}{3}}$$

$$\Rightarrow \omega = \sqrt{\frac{2Gm^2}{d^2 \cdot 2} \times \frac{3}{md}}$$

$$\Rightarrow \omega = \sqrt{\frac{3Gm}{d^3}}$$

$$\Rightarrow \frac{2\pi}{T} = \sqrt{\frac{3Gm}{d^3}} \Rightarrow T = 2\pi \sqrt{\frac{d^3}{3Gm}}$$

40. Option (1) is correct.

Let height of building be H .

For first stone:

$$u = 0$$

$v =$ velocity at 5 m

$$v^2 = u^2 + 2g \times 5$$

$$\Rightarrow v^2 = 0 + 2 \times 10 \times 5$$

$$\Rightarrow v = 10 \text{ m/s}$$

$$\text{Now, } H - 5 = 10t + \frac{1}{2}gt^2 \quad \dots(i)$$

For second stone :

$$H - 25 = \frac{1}{2}gt^2 \quad \dots(ii)$$

From equation (i) and (ii)

$$\Rightarrow \frac{1}{2}gt^2 + 20 = 10t + \frac{1}{2}gt^2$$

$$\Rightarrow t = \frac{20}{10} = 2 \text{ s}$$

$$t = 2 \text{ s}$$

Now, substituting the value of t in equation (ii)

$$H - 25 = \frac{1}{2} \times 10 \times 4$$

$$\Rightarrow H = (20 + 25) \text{ m}$$

$$\Rightarrow H = 45 \text{ m}$$

41. Option (4) is correct.

Given,

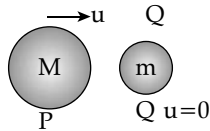

$$m \ll M$$

For elastic collision,

$$e = \frac{V_2 - V_1}{u_1 - u_2}$$

$$e = 1$$

$$1 = \frac{V_2 - V_1}{u - 0}$$

$$V_2 - V_1 = 4 \quad \dots(i)$$

When momentum is conserved, then

$$Mu + 0 = mV_1 + MV_2$$

$$\text{(if } M = m) u = V_1 + V_2 \quad \dots(ii)$$

from equations (i) and (ii)

$$\Rightarrow V_2 = 2u$$

Hence, in elastic collision, the kinetic energy and momentum always be conserve.

42. Option (2) is correct.

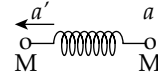

$$F - F_s = Ma'$$

$$\Rightarrow a' = \frac{F}{M} - \frac{F_s}{M} \Rightarrow a' = \frac{F}{M} - a$$

$$\Rightarrow a' = \frac{F - Ma}{M}$$

43. Option (4) is correct.

Given, $m = 200 \text{ g}$, $r = 20 \text{ cm}$, $T = 40 \text{ s}$

Using the expression $T = \frac{2\pi}{\omega}$

$$\omega = \frac{2\pi}{40} = \frac{\pi}{20} = \frac{3.14}{20} \text{ radian/second}$$

Normal force will provide the necessary centripetal force.

$$N = m r \omega^2 = \left(\frac{200}{1000} \right) \left(\frac{20}{100} \right) \left[\frac{3.14}{20} \right]^2$$

$$= 9.859 \times 10^{-4} \text{ N}$$

44. Option (1) is correct.

Using first equation of motion

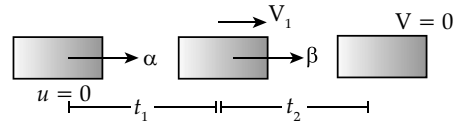

$$V_1 = \alpha t_1$$

$$0 = \alpha t_1 - \beta t_2$$

$$t_2 = \frac{\alpha}{\beta} t_1$$

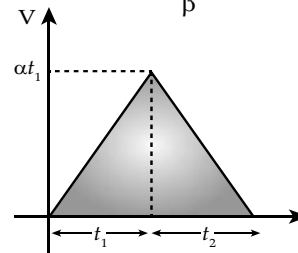

$$\text{Total time } (t) = [t_1 + t_2]$$

$$t = t_1 + \frac{\alpha}{\beta} t_1 \Rightarrow \left[\frac{\beta}{\alpha + \beta} \right] t = t_1$$

Area of triangle [Distance]

$$= \frac{1}{2} [t_1 + t_2] [\alpha t_1] = \frac{1}{2} t^2 \alpha \left[\frac{\beta}{\alpha + \beta} \right]$$

45. Option (1) is correct.

$$v = \frac{dx}{dt} = \text{slope is increasing}$$

So, velocity increases

$$\frac{dv}{dt} = a = \text{constant}$$

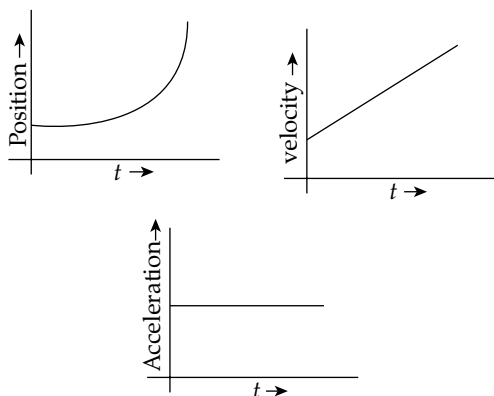

46. **Option (4) is correct.**
As the slope of velocity vs displacement graph is negative,

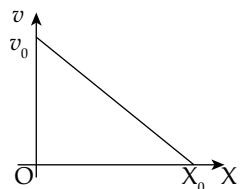

So,
$$a = v \frac{dv}{dx}$$

$\Rightarrow \frac{dv}{dx} \rightarrow (-)$

As we increase the displacement, acceleration will decrease in negative.

47. **Option (4) is correct.**
Mass of a steel block is 10 kg.

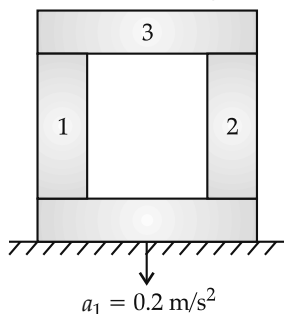

Mass of all cylinder $M = 20 \times 3 + 10 = 70$ kg

The force equation in vertical direction

$$Mg - N = Ma$$

$$70 \times 10 - N = 70 \times 0.2$$

$$N = 70[10 - 0.2] = 686 \text{ N}$$

48. **Option (4) is correct.**
Friction (f) = $\mu N = (0.2) N$

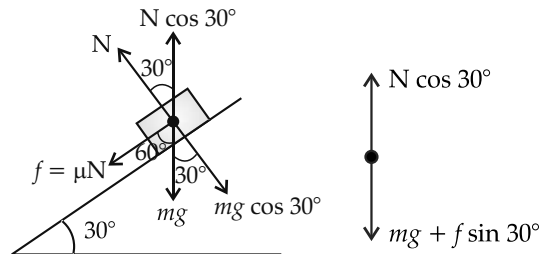

Equation of motion in vertical direction

$$N \cos 30^\circ - \mu N \cos 60^\circ = mg$$

$$N = \frac{800 \times 10}{\cos 30^\circ - 0.2 \times \cos 60^\circ}$$

$$= 10.4 \times 10^3 \text{ kg m/s}^2 \approx 10.2 \times 10^3 \text{ kg m/s}^2$$

49. **Option (3) is correct.**
The muzzle velocity of bullet is 50 m/s
Apply conservation of momentum

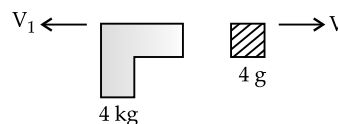

$$4 \times 10^{-3} [50 - V_1] = 4V_1$$

$$V_1 = \frac{4 \times 10^{-3} \times 50}{4 + 4 \times 10^{-3}}$$

$$= 0.05 \text{ m/s}$$

$$v = 50 - v_1$$

$$[\text{Impulse}]_{\text{Gun}} = 4 \times 0.05$$

$$= 0.2 \text{ kg m/s}$$

$$[\text{Impulse}]_{\text{bullet}} = 4 \times 10^{-3} [50 - 0.05]$$

$$= 0.2 \text{ kg m/s}$$

50. **Option (2) is correct.**
Impulse = change in momentum
= final momentum - initial momentum
for ball (1) Impulse = $2 \mu u$
for ball (2) Impulse = $2 \mu u \cos 45^\circ$

$$\text{Ratio for ball } a \text{ and } b = \sqrt{2} / 1$$

51. **Option (2) is correct.**
- $$\vec{F} = m\vec{a} = 40\hat{i} + 10\hat{j}$$
- $$\vec{a} = 8\hat{i} + 2\hat{j}$$
- $$\vec{r} = \frac{1}{2}\vec{a}t^2 = \frac{1}{2}(8\hat{i} + 2\hat{j})(10)^2$$
- $$= (400\hat{i} + 100\hat{j})$$

52. **Option (1) is correct.**
A makes elastic collision with B

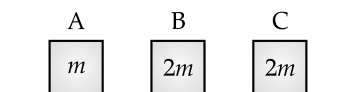

Apply conservation of momentum

$$9 m = 2mv_1 + mv_2 \quad \dots(i)$$

$$\frac{1}{2}m(81) = \frac{1}{2}2mv_1^2 + \frac{1}{2}mv_2^2 \quad \dots(ii)$$

$$2mv_1 = 4mv_2$$

$$v_2 = \frac{v_1}{2}$$

By solving (i) and (ii)

$$v_2 = \frac{6}{2} = 3 \text{ m/s}$$

53. Option (3) is correct.

$$B_a = \frac{\mu_0 I}{2\pi a}$$

$$B_b = \frac{\mu_0 I}{2\pi b}$$

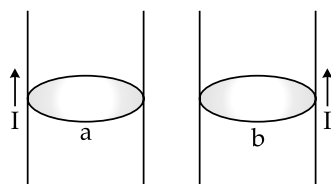

$$b > a$$

$$B_a > B_b$$

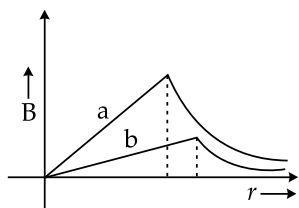

54. Option (1) is correct.

Rocket is example of variable mass system. If rate of loss of mass be $\frac{dm}{dt}$ and the gas leaves rocket relative speed of V_g then

$$\text{Upthrust} = F = \frac{dm}{dt} \cdot V_g$$

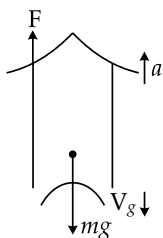

From free body diagram

$$F - mg = ma$$

$$\Rightarrow \frac{dm}{dt} \cdot V_g - mg = ma$$

$$\frac{dm}{dt} = \frac{m(g+a)}{V_g} = \frac{1000(10+20)}{500}$$

$$\frac{dm}{dt} = 2 \times 30 = 60 \text{ kg/s}$$

55. Option (4) is correct.

Breaking stress of wire passing over pulley are given $\frac{24}{\pi} \times 10^2 \text{ N/m}^2$. In this question, the tension T in wire will be creating breaking stress.

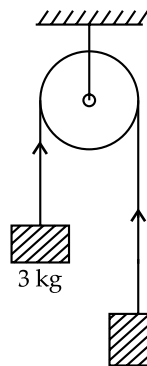

$$\text{Breaking stress} = \frac{T}{\text{Area}} = \frac{T}{\pi R^2}$$

$$\frac{24}{\pi} \times 10^2 = \frac{T}{\pi R^2}$$

$$\Rightarrow R = \sqrt{\frac{T}{\pi \times \frac{24}{\pi} \times 10^2}} \quad \dots(i)$$

Now, Tension can be found using equations

$$T = \left(\frac{2m_1 + m_2}{m_1 + m_2} \right) g = \frac{2 \times 3 + 5 \times 10}{3 + 5} = \frac{75}{2} \text{ N}$$

Putting value of T in equation (i)

$$R = \sqrt{\frac{75/2}{\pi \times \frac{24}{\pi} \times 10^2}} = \sqrt{\frac{3}{8 \times 24}} \text{ m}$$

$$R = 12.5 \text{ cm}$$

56. Option (3) is correct.

Concept :

When mass tied with string is made to rotate in horizontal circle, the tension in string is T.

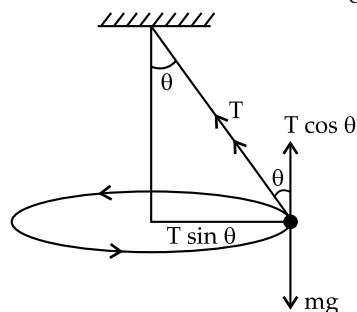

The weight of body is balanced by $T \cos \theta$

$$T \cos \theta = mg \quad \dots(i)$$

and $T \sin \theta = \frac{mv^2}{r} \quad \dots(ii)$

(it gives required centripetal force)

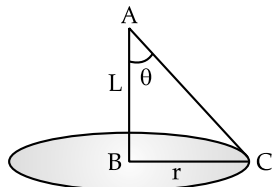

Here given $r = \frac{1}{\sqrt{2}}$

From ΔABC , $\tan \theta = \frac{r}{L} = \frac{1}{\sqrt{2}}$

$$\theta = 45^\circ$$

From eqn (i) and eqn (ii)

$$\frac{T \sin \theta}{T \cos \theta} = \frac{mv^2/r}{mg} = \frac{v^2}{rg}$$

$$\tan \theta = \frac{v^2}{rg}$$

$$\Rightarrow \tan 45 = \frac{v^2}{rg}$$

$$v = \sqrt{rg}$$

57. Option (4) is correct.

It is special case of Pully. When pully B goes down by $2x$ distance 2 kg block moves up by x .

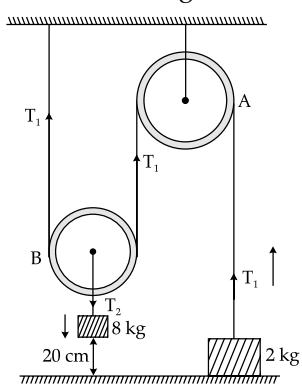

So acceleration of 2 kg box is ' a ' acceleration of 8 kg box is ' $2a$ '. Drawing free body diagram for each box.

For 2 kg box, $T_1 - m_1g = m_1a$
 $\Rightarrow T_1 - 2g = 2a \quad \dots(i)$

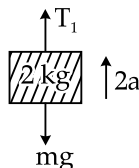

For 8 kg box, $8g - T_2 = 8a \quad \dots(ii)$

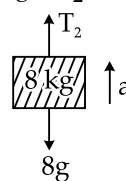

From pully B $2T_1 = T_2$

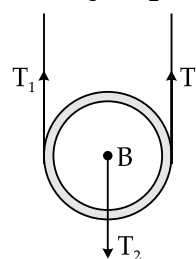

Put value of T_2 in equation (ii)

$$8g - 2T_1 = 8a \quad \dots(iii)$$

$$T_1 - 2g = 2a \quad \dots(iv)$$

Solving above two equations, we get

$$a = \frac{4}{16}g = g/a = \frac{10}{4} = 2.5 \text{ m/s}^2$$

Time taken by 8 kg box to hit the ground

$$s = ut + \frac{1}{2}at^2,$$

$$u = 0, a = 2.5 \text{ m/s}^2$$

$$t = \sqrt{\frac{2s}{a}} = \sqrt{\frac{2 \times 20 \times 10^{-2}}{2.5}}$$

$$= 0.4 \text{ sec}$$

58. Option (4) is correct.

Given : The rate of increase of mass of a spaceship is

$$\frac{dM(t)}{dt} = bv^2(t)$$

To find : a , the instantaneous acceleration of the space ship.

Force acting on the space ship due to increase in its mass :

$$F = v(t) \frac{dM(t)}{dt}$$

$$a = \frac{F}{M} = \frac{1}{M} \left(v(t) \frac{dM(t)}{dt} \right)$$

$$a = \frac{1}{M} (v \times bv^2) = \frac{bv^3}{M}$$

59. Option (3) is correct.

Given : Speed of particle moving in a circular path,

$$v = 10 \text{ m/s},$$

To find: $|\Delta v|$, magnitude of change in velocity of the particle, when it moves through an angle of $\theta = 60^\circ$ around the centre of the circle.

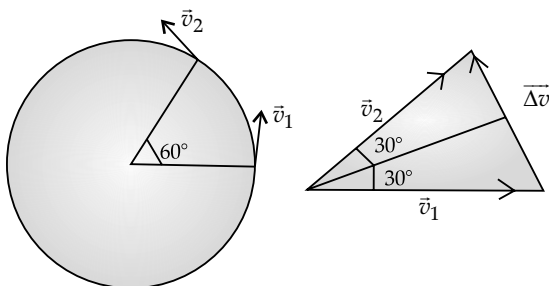

From the diagram above :

$$\begin{aligned} \Delta \vec{v} &= \vec{v}_2 - \vec{v}_1 \\ |\Delta \vec{v}| &= 2v \sin \frac{\theta}{2} \left(|\vec{v}_1| = |\vec{v}_2| = v, \theta = 60^\circ \right); \\ |\Delta \vec{v}| &= 2 \times 10 \times \sin 30^\circ = 10 \text{ m/s} \end{aligned}$$

60. Option (4) is correct.

$$\begin{aligned} \tan \theta &= \frac{v^2}{rg} \\ \Rightarrow \tan \theta &= \sqrt{rg \tan \theta} \\ \Rightarrow &= \sqrt{(10)(9.8) \tan 10^\circ} \\ &= 4.2 \text{ m/s} \end{aligned}$$

61. Option (3) is correct.

$$\begin{aligned} \frac{mv^2}{r} &= fs \text{ (max)} \\ &\text{(To prevent car from slipping)} \\ \Rightarrow \frac{mv^2}{r} &= \mu smg \\ \Rightarrow \mu s &= \frac{v^2}{rg} = \frac{(15)^2}{20 \times 9.8} = 1.15 \\ &\text{(\because } 54 \text{ km/h} = 15 \text{ ms}^{-1}\text{)} \end{aligned}$$



Topic-2 Frictional Forces



JEE (Main) Previous Year Questions

Multiple Choice Questions

1. A body of mass 10 kg is moving with an initial speed of 20 m/s. The body stops after 5 s due to friction between body and the floor. The value of the coefficient of friction is: (Take acceleration due to gravity, $g = 10 \text{ m s}^{-2}$)

(1) 0.3 (2) 0.5 (3) 0.2 (4) 0.4

[JEE (Main) – 31st Jan. 2023 - Shift-2]

2. The time taken by an object to slide down 45° rough inclined plane is n times as it takes to slide down a perfectly smooth 45° incline plane. The coefficient of kinetic friction between the object and the incline plane is:

(1) $\sqrt{1 - \frac{1}{n^2}}$ (2) $1 + \frac{1}{n^2}$ (3) $1 - \frac{1}{n^2}$ (4) $\sqrt{\frac{1}{1 - n^2}}$

[JEE (Main) – 29th Jan. 2023 - Shift-2]

3. A car is moving on a horizontal curved road with radius 50 m. The approximate maximum speed of car will be, if friction between tyres and road is 0.34. (take $g = 10 \text{ m s}^{-2}$)

(1) 17 m s^{-1} (2) 13 m s^{-1}
(3) 22.4 m s^{-1} (4) 3.4 m s^{-1}

[JEE (Main) – 29th Jan. 2023 - Shift-1]

4. A block of mass m slides down the plane inclined at angle 30° with an acceleration $\frac{g}{4}$. The value of coefficient of kinetic friction will be:

(1) $\frac{1}{2\sqrt{3}}$ (2) $\frac{\sqrt{3}}{2}$ (3) $\frac{2\sqrt{3}+1}{2}$ (4) $\frac{2\sqrt{3}-1}{2}$

[JEE (Main) – 29th Jan. 2023 - Shift-1]

5. Consider a block kept on an inclined plane (inclined at 45°) as shown in the figure. If the force required to just push it up the incline is 2

times the force required to just prevent it from sliding down, the coefficient of friction between the block and inclined plane (μ) is equal to:

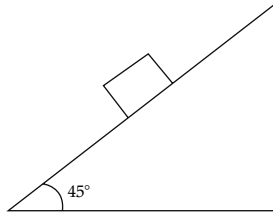

- (1) 0.25 (2) 0.50 (3) 0.60 (4) 0.33

[JEE (Main) – 25th Jan. 2023 - Shift-2]

6. A block of mass 10 kg starts sliding on a surface with an initial velocity of 9.8 ms^{-1} . The coefficient of friction between the surface and block is 0.5. The distance covered by the block before coming to rest is : [use $g = 9.8 \text{ ms}^{-2}$]

- (1) 4.9 m (2) 9.8 m (3) 12.5 m (4) 19.6 m

[JEE (Main) – 24th June 2022 - Shift-1]

7. A boy ties a stone of mass 100 g at the end of a 2 m long string and whirls it around in a horizontal plane. The string can withstand the maximum tension of 80 N. If the maximum speed with which the stone can revolve is $\frac{K \text{ rev}}{\pi \text{ min}}$. The value of K is :

(Assume the string is massless and unstretchable)

- (1) 400 (2) 300 (3) 600 (4) 800

[JEE (Main) – 24th June 2022 - Shift-1]

8. One end of a massless spring of spring constant k and natural length l_0 is fixed while the other end is connected to a small object of mass m lying on a frictionless table. The spring remains horizontal on the table. If the object is made to rotate at an angular velocity ω about an axis passing through fixed end, then the elongation of the spring will be :

(1) $\frac{k - m\omega^2 l_0}{m\omega^2}$ (2) $\frac{m\omega^2 l_0}{k + m\omega^2}$

(3) $\frac{m\omega^2 l_0}{k - m\omega^2}$ (4) $\frac{k + m\omega^2 l_0}{m\omega^2}$

[JEE (Main) – 27th June 2022 - Shift-2]

9. A system of two blocks of masses $m = 2 \text{ kg}$ and $M = 8 \text{ kg}$ is placed on a smooth table as shown in figure. The coefficient of static friction between two blocks is 0.5. The maximum horizontal force F that can be applied to the block of mass M so that the blocks move together will be:

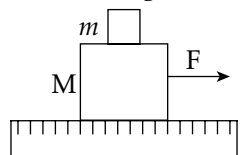

- (1) 9.8 N (2) 39.2 N (3) 49 N (4) 78.4 N

[JEE (Main) – 27th June 2022 - Shift-1]

10. A block of mass M slides down on a rough inclined plane with constant velocity. The angle made by the incline plane with horizontal is θ . The magnitude of the contact force will be :

- (1) Mg
 (2) $Mg \cos \theta$
 (3) $\sqrt{Mg \sin \theta + Mg \cos \theta}$
 (4) $Mg \sin \theta \sqrt{1 + \mu}$

[JEE (Main) – 27th July 2022 - Shift-2]

11. A bag is gently dropped on a conveyor belt moving at a speed of 2 m/s. The coefficient of friction between the conveyor belt and bag is 0.4. Initially, the bag slips on the belt before it stops due to friction. The distance travelled by the bag on the belt during slipping motion, is : [Take $g = 10 \text{ m/s}^2$]

- (1) 2 m (2) 0.5 m (3) 3.2 m (4) 0.8 m

[JEE (Main) – 27th July 2022 - Shift-1]

12. A uniform metal chain of mass m and length ' L ' passes over a massless and frictionless pulley. It is released from rest with a part of its length ' l ' hanging on one side and rest of its length ' $L - l$ ' hanging on the other side of the pulley.

At a certain point of time, when $l = \frac{L}{x}$ the acceleration of the chain is $\frac{g}{2}$. The value of x is

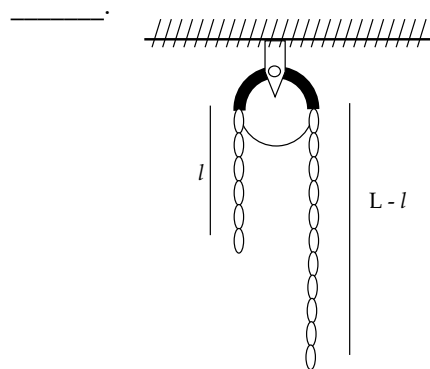

- (1) 6 (2) 2 (3) 1.5 (4) 4

[JEE (Main) – 28th July 2022 - Shift-2]

13. A 1 m long wire is broken into two unequal parts X and Y. The X part of the wire is stretched into another wire W. Length of W is twice the length of X and the resistance of W is twice that of Y. Find the ratio of length of X and Y.

- (1) 1 : 4 (2) 1 : 2 (3) 4 : 1 (4) 2 : 1

[JEE (Main) – 29th July 2022 - Shift-2]

14. Two bodies of masses $m_1 = 5 \text{ kg}$ and $m_2 = 3 \text{ kg}$ are connected by a light string going over a smooth light pulley on a smooth inclined plane as shown in the figure. The system is at rest. The force exerted by the inclined plane on the body of mass m_1 will be : [Take $g = 10 \text{ ms}^{-2}$]

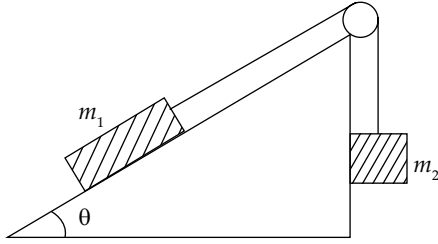

- (1) 30 N (2) 40 N (3) 50 N (4) 60 N

[JEE (Main) – 29th July 2022 - Shift-2]

15. A particle is moving with uniform speed along the circumference of a circle of radius R under the action of a central fictitious force F which is inversely proportional to R^3 . Its time period of revolution will be given by :

- (1) $T \propto R^{\frac{5}{2}}$ (2) $T \propto R^2$ (3) $T \propto R^{\frac{4}{3}}$ (4) $T \propto R^{\frac{3}{2}}$

[JEE (Main) – 26th Feb. 2021 - Shift-1]

16. A block of mass m slides along a floor while a force of magnitude F is applied to it at an angle θ as shown in figure. The coefficient of kinetic friction is μ_K . Then, the block's acceleration ' a ' is given by :

(g is acceleration due to gravity)

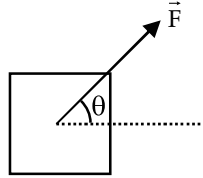

- (1) $\frac{F}{m} \cos \theta - \mu_K \left(g - \frac{F}{m} \sin \theta \right)$
 (2) $\frac{F}{m} \cos \theta - \mu_K \left(g + \frac{F}{m} \sin \theta \right)$
 (3) $\frac{F}{m} \cos \theta + \mu_K \left(g - \frac{F}{m} \sin \theta \right)$
 (4) $-\frac{F}{m} \cos \theta - \mu_K \left(g - \frac{F}{m} \sin \theta \right)$

[JEE (Main) – 16th March 2021 - Shift-1]

17. A block of mass m slide on the wooden wedge, which in turn slides backward on the horizontal surface. The acceleration of the block with respect to the wedge is: Given $m = 8$ kg, $M = 16$ kg. Assume all the surface shown in the figure to be frictionless.

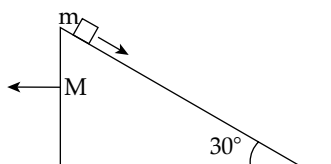

- (1) $\frac{4}{3}g$ (2) $\frac{2}{3}g$ (3) $\frac{3}{5}g$ (4) $\frac{6}{5}g$

[JEE (Main) – 1st Sep. 2021 - Shift-2]

18. A 60 HP electric motor lifts an elevator having a maximum total load capacity of 2000 kg. If the frictional force on the elevator is 4000 N, the speed of the elevator at full load is close to :

(1 HP = 746 W, $g = 10 \text{ ms}^{-2}$)

- (1) 1.5 ms^{-1} (2) 1.7 ms^{-1} (3) 2.0 ms^{-1} (4) 1.9 ms^{-1}

[JEE (Main) – 7th Jan. 2020 - Shift-1]

19. To mop-clean a floor, a cleaning machine presses a circular mop of radius R vertically down with a total force F and rotates it with a constant angular speed about its axis. If the force F is distributed uniformly over the mop and if coefficient of friction between the mop and the floor is μ , the torque, applied by the machine on the mop is :

- (1) $\mu FR/3$ (2) $\mu FR/6$ (3) $\mu FR/2$ (4) $\frac{2}{3} \mu FR$

[JEE (Main) – 10th Jan. 2019 Shift-1]

ANSWER – KEY

01. (4)	02. (3)	03. (2)	04. (1)
05. (4)	06. (2)	07. (3)	08. (3)
09. (3)	10. (1)	11. (2)	12. (4)
13. (2)	14. (2)	15. (2)	16. (1)
17. (2)	18. (4)	19. (4)	

ANSWERS WITH EXPLANATIONS

1. Option (4) is correct.

Given $m = 10$ kg, $u = 20 \text{ m s}^{-1}$
 $v = 0 \text{ m s}^{-1}$, $t = 5$ s, $\mu = ?$

Using first equation of motion

$$a = \frac{v - u}{t}$$

$$\Rightarrow a = \frac{0 - 20}{5} = -4 \text{ m s}^{-2}$$

Now the force causing this acceleration will be

$$F = ma = 10 \times -4 = -40 \text{ N}$$

This force is equal to friction force

$$f = F$$

$$\Rightarrow \mu mg = 40$$

$$\Rightarrow \mu = \frac{40}{mg} = \frac{40}{100} = 0.4$$

2. Option (3) is correct.

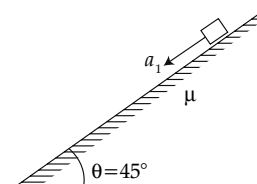
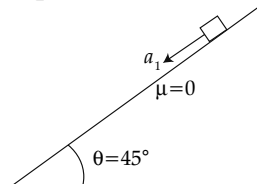

Acceleration of object on smooth inclined plane
 $= g \sin 45^\circ = g/\sqrt{2}$

Acceleration of object on rough inclined plane
 $= g(\sin \theta - \mu \cos \theta)$
 $= \frac{g}{\sqrt{2}}(1 - \mu)$

If it takes t_1 second to slide down on smooth plane and t_2 second to slide down on rough inclined plane, it is given that

$$t_2 = n t_1$$

by

$$t = \sqrt{\frac{2s}{a}}$$

$$\sqrt{\frac{2s}{a_2}} = n \sqrt{\frac{2s}{a_1}} \Rightarrow \frac{1}{a_2} = \frac{n^2}{a_1}$$

$$a_1 = n^2 a_2$$

$$\frac{g}{\sqrt{2}} = n^2 \frac{g}{\sqrt{2}}(1 - \mu)$$

$$1 - \mu = \frac{1}{n^2} \Rightarrow \mu = 1 - \frac{1}{n^2}$$

3. Option (2) is correct.

We know that $f_s = \frac{mv^2}{r}$

Maximum speed for safe turning

$$f_s = f_{s \max} = \mu mg$$

$$v_{\max} = \sqrt{\mu rg}$$

$$= \sqrt{0.34 \times 50 \times 10} = 13 \text{ m/s}$$

4. Option (1) is correct.

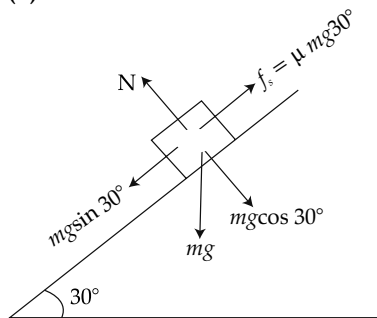

Resolving the force along inclined plane

$$mg \sin 30^\circ - \mu mg \cos 30^\circ = ma$$

$$\Rightarrow \frac{g}{2} - \frac{\sqrt{3}}{2} \mu g = \frac{g}{4} \Rightarrow \frac{\sqrt{3}}{2} \mu = \frac{1}{4} \Rightarrow \mu = \frac{1}{2\sqrt{3}}$$

5. Option (4) is correct.

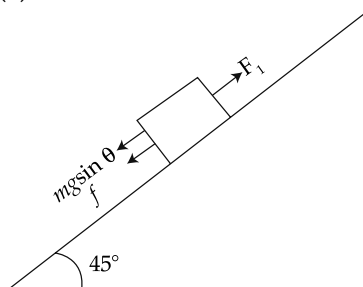

In order to just push the block up (acceleration = 0),

$$F_1 = mg \sin \theta + \mu mg \cos \theta$$

$$F_1 = \frac{mg}{12} + \frac{\mu mg}{12} = \frac{mg}{\sqrt{2}}(1 + \mu)$$

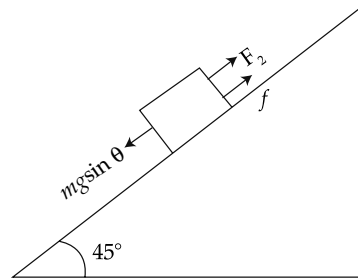

In order to just prevent it from sliding down,

$$F_2 = mg \sin \theta + \mu mg \cos \theta$$

$$F_2 = \frac{mg}{\sqrt{2}} - \frac{\mu mg}{\sqrt{2}} = \frac{mg}{\sqrt{2}}(1 - \mu)$$

Given that

$$F_1 = 2F_2$$

$$\frac{mg}{\sqrt{2}}(1 + \mu) = 2 \times \frac{mg}{\sqrt{2}}(1 - \mu)$$

$$1 + \mu = 2(1 - \mu)$$

$$3\mu = 1$$

$$\mu = \frac{1}{3} = 0.33$$

6. Option (2) is correct.

Applying the law of COE we get

$$\frac{1}{2} mu^2 = (\mu mg) d$$

Where d = distance travelled by the block before coming to rest

$$d = \frac{u^2}{2\mu g} = \frac{9.8 \times 9.8}{2 \times 0.5 \times 9.8} = 9.8 \text{ m}$$

7. Option (3) is correct.

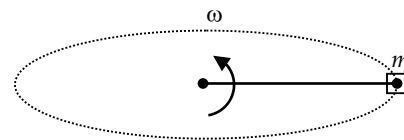

The tension in the string provides centripetal force

$$T = m\omega^2 l$$

$$\omega^2 = \frac{T}{ml} = \frac{80}{0.1 \times 2} = 400$$

$$\omega = 20 \text{ rad/s}$$

$$= 20 \times \frac{60}{2\pi} \text{ rev/min} = \frac{K}{\pi} \text{ rev/min}$$

$$K = 600$$

8. Option (3) is correct.

Here spring force will provide required centripetal force, to move on circular path

Spring force = centripetal force

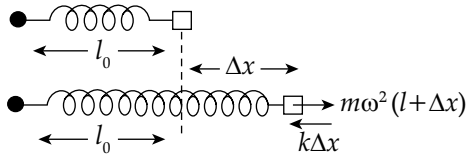

$$k\Delta x = m\omega^2(l_0 + \Delta x)$$

$$k\Delta x = ml_0\omega^2 + m\omega^2\Delta x$$

$$\Delta x = \frac{ml_0\omega^2}{k - m\omega^2}$$

9. Option (3) is correct.

Let a be the acceleration with which both blocks move together.

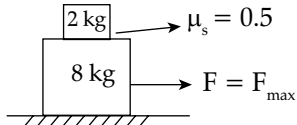

In this case when whole system of masses move with common acceleration a then the mass of 2 kg experiences a pseudo force in opposite direction, in result of which a frictional force develops to prevent motion in limiting case

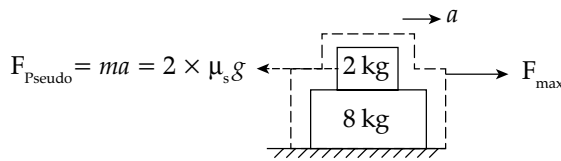

$$\Rightarrow a = \mu_s g = 0.5 \times 9.8 = 4.9 \text{ m/s}^2$$

So the maximum force applied on 10 kg block

$$F_{\text{max}} = (m + M) a$$

$$F_{\text{max}} = (2 + 8) \times 4.9 = 49 \text{ N}$$

10. Option (1) is correct.

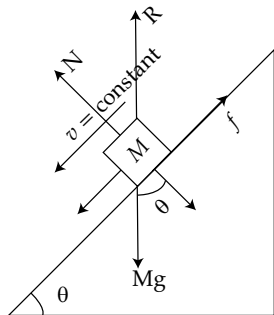

Since block slides with constant velocity
 $a = 0$

$$\text{Frictional force } f = Mg \sin \theta$$

$$N = Mg \cos \theta$$

$$\text{Contact force } R = \sqrt{f^2 + N^2}$$

$$= \sqrt{(Mg \sin \theta)^2 + (Mg \cos \theta)^2} = Mg$$

11. Option (2) is correct.

Given velocity of conveyor belt = 2 m/s

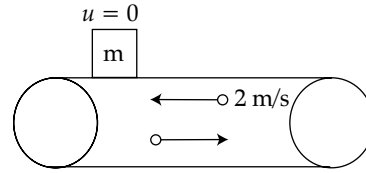

Consider motion of the block with belt

$$u_{\text{net}} = 0 - (-2) = 2 \text{ m/s}$$

$$a_{\text{net}} = \frac{f}{m} = \frac{\mu mg}{m} = \mu g = 0.4 \times 10 = 4 \text{ m/s}^2$$

Applying $v_{\text{net}}^2 = u_{\text{net}}^2 + 2a_{\text{net}}r_{\text{net}}$

$$0 = (2)^2 - 2(4)r_{\text{net}}$$

$$r_{\text{net}} = 0.5 \text{ m}$$

12. Option (4) is correct

Mass of length $l, m_1 = \frac{M}{L}l$

Mass of length $L-l, m_2 = \frac{M}{L}(L-l)$

Total mass of chain $M = m_1 + m_2$

From newton's laws of motion

$$m_2 g - m_1 g = (m_2 + m_1) \frac{g}{2}$$

$$\Rightarrow \frac{M}{L}(L-l)g - \frac{M}{L}(l)g = M \frac{g}{2}$$

$$\Rightarrow L-l-l = \frac{L}{2}$$

$$\Rightarrow l = \frac{L}{4}$$

Comparing with given eq. $l = \frac{L}{x}$, we get $x = 4$

13. Option (2) is correct

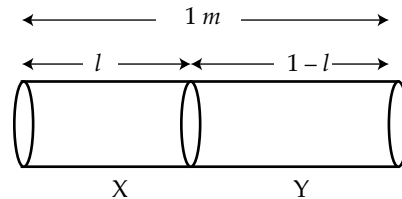

As we know resistance is directly proportional to length of wire $R \propto l$

$$\text{So, } \frac{R_X}{R_Y} = \frac{l_X}{l_Y} \tag{1}$$

The wire 'X' is stretched two times of its length and its resistance becomes 4 times of X.

$$R_X = \rho l_X / A = \rho l_X^2 / V$$

$$R_w = \rho l_w / A = \rho l_w^2 / V = 4R_X$$

$$R_w = 4R_X = 2R_Y$$

$$\frac{R_X}{R_Y} = \frac{1}{2} \Rightarrow \text{so } \frac{l_X}{l_Y} = \frac{1}{2}$$

14. Option (2) is correct

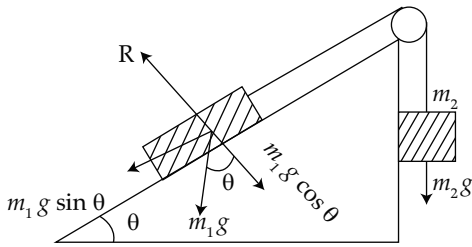

For the given arrangement of masses m_1 and m_2 , are in equilibrium position.

$$m_2 g = m_1 g \sin \theta \Rightarrow m_2 = m_1 \sin \theta$$

$$\sin \theta = \frac{m_2}{m_1} = \frac{3}{5} \Rightarrow \cos \theta = \frac{4}{5}$$

Normal reaction on m_1

$$R = m_1 g \cos \theta = 5 \times 10 \times \frac{4}{5} = 40 \text{ N}$$

15. Option (2) is correct.

Given,

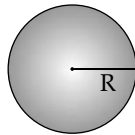

$$F \propto \frac{1}{R^3} \Rightarrow F = \frac{k}{R^3}$$

Here k is proportionality constant

Now, centripetal force $\frac{mv^2}{R} = \frac{k}{R^3}$

$$\Rightarrow \frac{m(R\omega)^2}{R} = \frac{k}{R^3} \Rightarrow mR\omega^2 = \frac{k}{R^3}$$

$$\Rightarrow \left(\frac{2\pi}{T}\right)^2 = \frac{k}{mR^4} \Rightarrow \frac{1}{T} = \frac{1}{2\pi} \sqrt{\frac{k}{m}} \cdot \frac{1}{R^2}$$

$$T \propto R^2$$

16. Option (1) is correct.

Free body diagram of the block

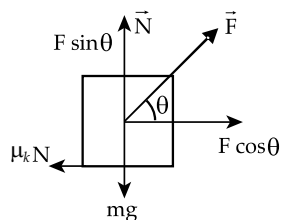

For equilibrium in the vertical direction

$$F \sin \theta + N = mg$$

$$N = mg - F \sin \theta \quad \dots(i)$$

$$\text{Also, } F \cos \theta - \mu_k N = ma \quad \dots(ii)$$

On solving (i) and (ii), we get

$$a = \frac{F}{m} \cos \theta - \mu_k \left[g - \frac{F}{m} \sin \theta \right]$$

17. Option (2) is correct.

When block of 8 kg slides down it pushes the 10 kg wedge in y -direction the push force is due to normal reaction force.

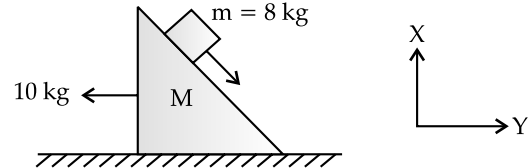

So let us draw FBD of 16 kg wedge

The component of reaction force N in $-X$ direction = $N \cos 60$

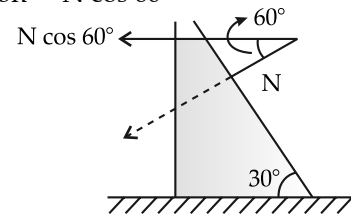

under $N \cos 60$, Wedge $M = 16 \text{ kg}$ moves so

$$N \cos 60 = Ma_1$$

where a_1 is acceleration of wedge.

$$\frac{N}{2} = Ma_1 = 16a_1$$

$$\Rightarrow N = 32a_1$$

Now FBD of 8 kg block with respect to wedge.

Forces on 8 kg block perpendicular to block

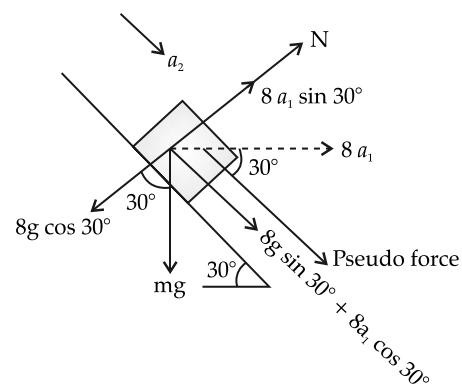

$$N = 8g \cos 30 - 8a_1 \sin 30$$

$$32a_1 = 8 \times 10 \times \frac{\sqrt{3}}{2} - 8 \times a_1 \times \frac{1}{2}$$

$$32a_1 = 40\sqrt{3} - 4a_1$$

$$36a_1 = 40\sqrt{3} \Rightarrow a_1 = \frac{40}{36}\sqrt{3}$$

$$a_1 = \frac{10}{9}\sqrt{3}$$

Along the inclined plane

$$8g \sin 30 + 8a_1 \cos 30 = 8a_2$$

$$8 \times 10 \times \frac{1}{2} + 8 \times a_1 \times \frac{\sqrt{3}}{2} = 8a_2$$

$$5 + a_1 \frac{\sqrt{3}}{2} = a_2$$

$$a_2 = 5 + \frac{10}{9} \times \sqrt{3} \times \frac{\sqrt{3}}{2}$$

$$= 5 + \frac{15}{9} = 5 + \frac{5}{3}$$

$$a_2 = \frac{20}{3} = 10 \times \frac{2}{3} = g \times \frac{2}{3}$$

$$a_2 = \frac{2g}{3}$$

18. Option (4) is correct.

Given : Maximum load capacity of an elevator is $M = 2000$ kg, frictional force acting on the elevator is $f = 4000$ N, power of electric motor attached to the elevator is $= 60$ HP, $1 \text{ HP} = 746$ W, $g = 10 \text{ m/s}^2$.

To find : v , speed of elevator at full load.

The net downward pull on the elevator is :

$$F = Mg + f = 2000 \times 10 + 4000 = 24000 \text{ N}$$

Power supplied by the electric motor to overcome the downward pull :

$$P = 60 \text{ HP} = 60 \times 746 \text{ W}$$

The speed of the elevator :

$$v = \frac{P}{F} = \frac{60 \times 746}{24000} \approx 1.9 \text{ m/s}$$

19. Option (4) is correct.

Given : Radius of mop = R , total force acting on the mop = F , coefficient of friction between the mop and the floor = μ .

To find : The torque applied by the machine on the mop.

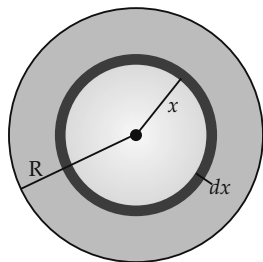

Torque acting on a small strip of mop of width dx and radius x :

$$d\tau = \text{Force per unit area} \times \text{area of the strip} \times \text{perpendicular distance from the axis.}$$

$$d\tau = \frac{\mu F}{\pi R^2} \times 2\pi x dx \times x = \frac{2\mu F x^2}{R^2} dx$$

Integrating the above equation to get the total torque :

$$\int d\tau = \frac{2\mu F}{R^2} \int_0^R x^2 dx = \frac{2\mu F}{R^2} \frac{R^3}{3}; \Rightarrow \tau = \frac{2}{3} \mu FR$$

Subjective Questions (Chapter Based)

- For a train engine moving with speed of 20 m s^{-1} , the driver must apply brakes at a distance of 500 m before the station for the train to come to rest at the station. If the brakes were applied at half of this distance, the train engine would cross the station with speed $\sqrt{x} \text{ m s}^{-1}$. The value of x is _____. (Assuming same retardation is produced by brakes).

[JEE (Main) – 1st Feb. 2023 - Shift-2]

Sol. Correct answer is [200].

$$\text{By } v^2 = u^2 - 2as \Rightarrow a = \frac{u^2}{2s} \Rightarrow a = \frac{400}{2 \times 500}$$

$$a = 4 \times 10^{-3} = 0.4 \text{ m s}^{-2}$$

$$\text{Now, } v^2 = 400 - 2 \times 0.4 \times 250$$

$$v^2 = 200 \Rightarrow v = \sqrt{200}$$

On comparison, $x = 200$

- A nucleus disintegrates into two nuclear parts, in such a way that ratio of their nuclear sizes is $1 : 2^{1/3}$. Their respective speed, have a ratio of $n : 1$. The value of n is _____.

[JEE (Main) – 11th April 2023 - Shift-2]

Sol. Correct answer is [2]

As per conservation of linear momentum,

$$\Rightarrow m_1 v_1 = m_2 v_2$$

$$\Rightarrow \frac{v_1}{v_2} = \frac{m_2}{m_1} = \frac{\rho \times \frac{4}{3} \times \pi \times r_2^3}{\rho \times \frac{4}{3} \times \pi \times r_1^3}$$

$$\Rightarrow \frac{v_1}{v_2} = \frac{r_2^3}{r_1^3} = \left(\frac{2^{1/3}}{1} \right)^3 = \frac{2}{1}$$

Comparing with $n : 1$, we get $n = 2$.

- A curve in a level road has a radius 75 m . The maximum speed of a car turning this curved road can be 30 m/s without skidding. If radius of curved road is changed to 48 m and the coefficient of friction between the tyres and the road remains same, then maximum allowed speed would be _____ m/s .

[JEE (Main) – 25th June 2022 - Shift-2]

Sol. Correct answer is [24]

$$v = \sqrt{\mu r g}$$

Where, r is the radius of the curved road

$$\frac{v_1}{v_2} = \sqrt{\frac{r_1}{r_2}}$$

$$\frac{30}{v_2} = \sqrt{\frac{75}{48}}$$

$$v_2 = 30\sqrt{\frac{48}{75}} = 30\sqrt{\frac{16 \times 3}{25 \times 3}} = 30 \times \frac{4}{5}$$

$$= 24 \text{ m/s}$$

4. A batsman hits back a ball of mass 0.4 kg straight in the direction of the bowler without changing its initial speed of 15 ms^{-1} . The impulse imparted to the ball is _____ Ns.

[JEE (Main) – 26th June 2022 - Shift-2]

Sol. Correct answer is [12]

Impulse = change in momentum

$$= 0.4 [u - (-u)]$$

$$= 2 \times 0.4 \times 15 = 12 \text{ kg m/s}$$

5. A mass of 10 kg is suspended vertically by a rope of length 5 m from the roof. A force of 30 N is applied at the middle point of rope in horizontal direction. The angle made by upper half of the rope with vertical is $\theta = \tan^{-1}(x \times 10^{-1})$. The value of x is _____.

(Given, $g = 10 \text{ m/s}^2$)

[JEE (Main) – 27th June 2022 - Shift-2]

Sol. Correct answer is [3].

Let T be tension in string. $T \cos\theta$ will balance weight and $T \sin\theta$ will balance force of 30 N

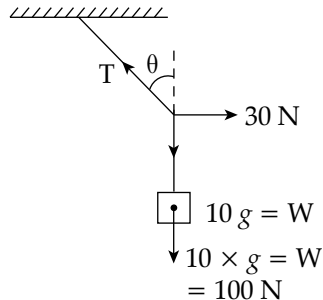

$$T \sin\theta = 30$$

$$T \cos\theta = 100$$

$$\tan\theta = 30/100 = 0.3$$

On comparing it with $x \times 10^{-1}$, we get

$$x = 3$$

6. A pendulum of length 2 m consists of a wooden bob of mass 50 g. A bullet of mass 75 g is fired towards the stationary bob with a speed v . The bullet emerges out of the bob with a speed $\frac{v}{3}$ and the bob just completes the vertical circle. The value of v is _____ ms^{-1} . (if $g = 10 \text{ m/s}^2$). [JEE (Main) – 27th June 2022 - Shift-1]

Sol. Correct answer is [10]

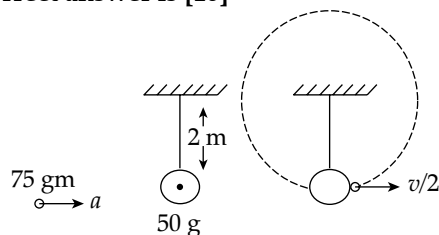

When bullet emerges it gives enough velocity to bob so that it completes vertical circle.

As we know that if it completes vertical circle of radius r , the speed at bottom should be $\sqrt{5gr}$.

Applying conservation of linear momentum

$$75v + 0 = 50\sqrt{5gr} + 75 \cdot \frac{v}{3}$$

$$75\left(v - \frac{v}{3}\right) = 50\sqrt{100}$$

$$v = 10 \text{ m/s}$$

7. A hanging mass M is connected to a four times bigger mass by using a string pulley arrangement, as shown in the figure. The bigger mass is placed on horizontal ice slab and being pulled by $2Mg$ force. In this situation, tension in the string is $\frac{x}{5} Mg$ for $x =$ _____.

Neglect mass of the string and friction of the block (bigger mass) with ice slab.

(Given $g =$ acceleration due to gravity)

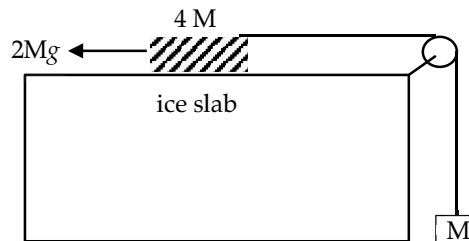

[JEE (Main) – 28th June 2022 - Shift-1]

Sol. Correct answer is [6]

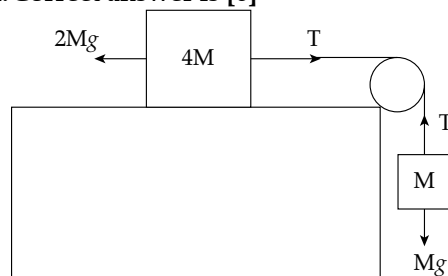

From FBD of the two blocks, as shown

$$2Mg - T = 4Ma \quad \dots(i)$$

$$T - Mg = Ma \quad \dots(ii)$$

Dividing eq. (i) by (ii)

$$\frac{2Mg - T}{T - Mg} = 4$$

$$\begin{aligned}
 2Mg - T &= 4T - 4Mg \\
 5T &= 6Mg \\
 T &= \frac{6}{5}Mg \\
 &= \frac{x}{5}Mg \\
 x &= 6
 \end{aligned}$$

8. Three identical spheres each of mass M are placed at the corners of a right angled triangle with mutually perpendicular sides equal to 3 m each. Taking point of intersection of mutually perpendicular sides as origin, the magnitude of position vector of centre of mass of the system will be $\sqrt{x}\text{ m}$. the value of x is _____.

[JEE (Main) – 25th July 2022 - Shift-2]

Sol. Correct answer is [2]

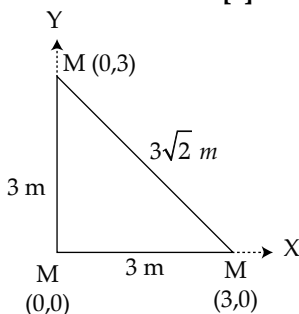

$$\begin{aligned}
 x_{cm} &= \frac{1}{3M} \sum Mx \\
 &= \frac{1}{3M} (M(0) + M(3) + M(0)) \\
 &= 1 \\
 y_{cm} &= \frac{1}{3M} \sum My \\
 &= \frac{1}{3M} (M(0) + M(0) + M(3)) \\
 &= 1 \\
 \vec{r}_{cm} &= \hat{i} + \hat{j} \\
 |\vec{r}_{cm}| &= \sqrt{2} = \sqrt{x} \\
 \Rightarrow x &= 2
 \end{aligned}$$

9. A particle is moving in a straight line such that its velocity is increasing at 5 ms^{-1} per meter. The acceleration of the particle is _____ ms^{-2} at a point where its velocity is 20 ms^{-1} .

[JEE (Main) – 25th July 2022 - Shift-2]

Sol. Correct answer is [100]

$$\begin{aligned}
 \frac{dv}{dx} &= 5 \\
 a = \frac{v dv}{dx} &= 20 \times 5 = 100\text{ m/s}^2
 \end{aligned}$$

10. A car is moving with speed of 150 km/h and after applying the break it will move 27 m before it stops. If the same car is moving with a speed of one third the reported speed then it will stop after travelling..... m distance

[JEE (Main) – 25th July 2022 - Shift-1]

Sol. Correct answer is [3]

$$\begin{aligned}
 \frac{1}{2}mv_1^2 &= fd_1 \text{ where } f = \text{force of friction} \\
 \frac{1}{2}mv_2^2 &= fd_2
 \end{aligned}$$

Dividing above equations, we get

$$\begin{aligned}
 \left(\frac{v_1}{v_2}\right) &= \frac{d_1}{d_2} \\
 d_2 &= d_1 \left(\frac{v_2}{v_1}\right)^2 = d_1 \left(\frac{1}{3}\right)^2 = \frac{d_1}{9} \\
 d_2 &= \frac{27}{9} = 3\text{ m}
 \end{aligned}$$

11. If the initial velocity in horizontal direction of a projectile is unit vector \hat{i} and the equation of trajectory is $y = 5x(1 - x)$. The Y component vector of the initial velocity is _____ \hat{j} (Take $g = 10\text{ m/s}^2$)

[JEE (Main) – 26th July 2022 - Shift-1]

Sol. Correct answer is [5]

$$\text{Given, } \vec{u}_x = \hat{i} \Rightarrow u_x = 1$$

Comparing given equation $y = 5x - 5x^2$ with standard equation of projectile

$$y = x \tan \theta - \frac{x^2 \tan^2 \theta}{R}, \text{ we get}$$

$$\tan \theta = 5$$

$$\frac{u_y}{u_x} = 5$$

$$u_y = 5 \times 1 = 5 \Rightarrow \vec{u}_y = 5\hat{j}$$

12. A ball of mass m is thrown vertically upward. Another ball of mass $2m$ is thrown at an angle θ with the vertical. Both the balls stay in air for the same period of time. The ratio of the heights attained by the balls respectively is $\frac{1}{x}$. The value of x is _____.

[JEE (Main) – 27th July 2022 - Shift-1]

Sol. Correct answer is [1:1]

For the ball thrown up vertically with v_1

$$\text{time of flight } T_1 = \frac{2v_1}{g}$$

For the ball thrown at an angle

θ vertical, with V_2

$$\text{time of flight } T_1 = \frac{2v_2 \cos \theta}{g}$$

Given that $T_1 = T_2$

$$\frac{2v_1}{g} = \frac{2v_2 \cos \theta}{g} \rightarrow v_2 \cos \theta = v_1 \quad \dots (i)$$

Now

$$H_1 = \frac{v_1^2}{2g} \text{ and } H_2 = \frac{v_2^2 \cos^2 \theta}{2g} = \frac{v_1^2}{2g} \quad (\text{from (i)})$$

$$\text{So } \frac{H_1}{H_2} = 1:1$$

13. A string of area of cross-section 4 mm^2 and length 0.5 m is connected with a rigid body of mass 2 kg . The body is rotated in a vertical circular path of radius 0.5 m . The body acquires a speed of 5 m/s at the bottom of the circular path. Strain produced in the string when the body is at the bottom of the circle is $\underline{\hspace{2cm}} \times 10^{-5}$ (use young's modulus 10^{11} N/m^2 and $g = 10 \text{ m/s}^2$) **[JEE (Main) – 28th July 2022 - Shift-2]**

Sol. Correct Answer is [30]

Given, Area of string, $A = 4 \text{ mm}^2 = 4 \times 10^{-6} \text{ m}^2$

Mass of rigid body, $m = 2 \text{ kg}$

Length of string, $l =$ radius of circle, $r = 0.5 \text{ m}$

Free body diagram at lowest point,

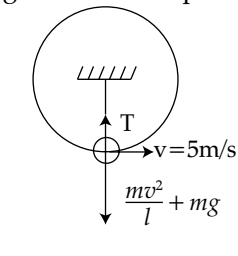

$$\text{At lowest point, } T = \frac{mv^2}{l} + mg$$

$$\Rightarrow T = F = \frac{2 \times 5^2}{0.5} + 2 \times 10 = 120 \text{ N}$$

Young's modulus of elasticity is given by,

$$\gamma = \frac{\text{stress}}{\text{strain}}$$

$$\Rightarrow \text{Strain} = \frac{\text{stress}}{\gamma} = \frac{120}{4 \times 10^{-6} \times 10^{11}}$$

$$\Rightarrow \text{Strain} = 30 \times 10^{-5}$$

14. A ball is thrown vertically upwards with a velocity of 19.6 ms^{-1} from the top of a tower. The ball strikes the ground after 6 s . The height from the ground up to which the ball can rise will be

$\left(\frac{k}{5}\right) \text{ m}$. The value of k is $\underline{\hspace{2cm}}$. (use $g = 9.8 \text{ m/s}^2$) **[JEE (Main) – 28th July 2022 - Shift-2]**

Sol. Correct answer is [392]

From top of tower to highest point.

$$v = 0, u = 19.6 \text{ m/s}, g = -9.8 \text{ m/s}^2$$

$$v^2 - u^2 = 2as.$$

$$0 - (19.6)^2 = 2 \times (-9.8) s$$

$$s = \frac{19.6 \times 19.6}{2 \times 9.8} = 19.6 \text{ m}$$

$$\text{Also, } s = ut + \frac{1}{2} gt^2$$

$$19.6 = 19.6 t + \frac{1}{2} (-9.8) t^2$$

$$4 = 4t - t^2$$

$$t^2 - 4t + 4 = 0$$

$$t = 2 \text{ s}$$

Time taken for upward journey of ball, $t = 2 \text{ s}$

Time taken for downward journey of ball,

$$t' = 6 - 2 = 4 \text{ s}$$

From highest point to the ground

$$u' = 0, t' = 4 \text{ s}, g = 9.8 \text{ m/s}^2$$

$$s' = u't' + \frac{1}{2} gt'^2$$

$$s' = 0 + \frac{1}{2} \times 9.8 \times 4 \times 4 = 78.4 \text{ m}$$

So, total height attained by the ball

$$= s' = 78.4 \text{ m} = \frac{392}{5} \text{ m}$$

$$\Rightarrow k = 392$$

15. A tube of length 50 cm is filled completely with an incompressible liquid of mass 250 g and closed at both ends. The tube is then rotated in the horizontal plane about one of its ends with a uniform angular velocity $x\sqrt{F}$ rad s^{-1} . If F be the force exerted by the liquid at the other end then the value of x will be $\underline{\hspace{2cm}}$.

[JEE (Main) – 29th July 2022 - Shift-2]

Sol. Correct answer is [4]

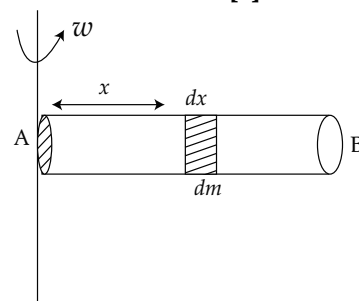

Let us take a differential element of mass dm and differential element of length dx at distance ' x ' from end A.

$$\text{Force exerted by liquid } F = \int dm \omega^2 x$$

$$F = \int_0^L \left(\frac{m}{L} dx\right) \omega^2 x$$

$$F = \frac{m\omega^2 L}{2}$$

$$\omega = \sqrt{\frac{2}{mL}} \cdot \sqrt{F}$$

$$\omega = \sqrt{\frac{2F}{0.25 \times 0.5}} = \sqrt{16F}$$

$$\omega = 4\sqrt{F}$$

16. A uniform chain of 6 m length is placed on a table such that a part of its length is hanging over the edge of the table. The system is at rest. The co-efficient of static friction between the chain and the surface of the table is 0.5, the maximum length of the chain hanging from the table is _____ m.

[JEE (Main) – 25th June 2022 - Shift-1]

Sol. Correct answer is [2]

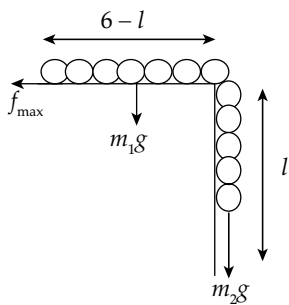

Let M be the total mass of the chain and l be the hanging length. Then

$$m_1 = \frac{M}{6}(6-l)$$

$$m_2 = \frac{M}{6}l$$

At equilibrium, $m_2 g = f_{\max} = \mu(m_1 g)$

On putting for m_1 and m_2 , we get

$$\left(\frac{M}{6}l\right)g = \mu \frac{M}{6}(6-l)g$$

$$l = \mu(6-l)$$

$$l = 0.5(6-l)$$

$$3l = 6$$

$$l = 2 \text{ m}$$

17. A ball with a speed of 9 m/s collides with another identical ball at rest. After the collision, the direction of each ball makes an angle of 30° with the original direction. The ratio of velocities of the balls after collision is $x : y$, where x is _____.

[JEE (Main) – 24th Feb. 2021 - Shift-1]

Sol. Correct answer is [1]

The balls are identical, so, $m_1 = m_2 = m$

Initial speed of first ball $u_1 = 9 \text{ m/s}$

Initial speed of second ball $u_2 = 0$

Applying the conservation of Linear Momentum

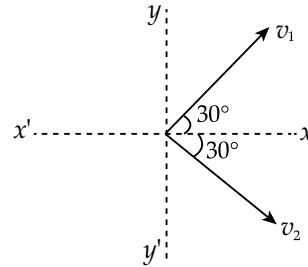

Momentum along y -axis

$$0 = mv_1 \sin 30^\circ - mv_2 \sin 30^\circ$$

$$v_1 = v_2 \Rightarrow v_1 : v_2 = 1 : 1$$

Momentum along x -axis

$$mu_1 + 0 = mv_1 \cos 30^\circ + mv_2 \cos 30^\circ$$

$$\text{or, } 9 = v_1 \times \frac{\sqrt{3}}{2} + v_1 \times \frac{\sqrt{3}}{2}$$

$$\text{or, } v_1 = v_2 = 3\sqrt{3}$$

$$\Rightarrow v_1 : v_2 = 1 : 1$$

Hence, the ratio of velocities of ball after collision is $x : y = 1 : 1$, where $x = 1$.

18. A boy pushes a box of mass 2 kg with a force $\vec{F} = (20\hat{i} + 10\hat{j}) \text{ N}$ on a frictionless surface. If the box was initially at rest, then _____ m is displacement along the x -axis after 10 s.

[JEE (Main) – 26th Feb. 2021 - Shift-1]

Sol. Correct answer is [500]

Given, Mass of box (m) = 2 kg

Force (\vec{F}) = $20\hat{i} + 10\hat{j} \text{ N}$

Displacement of box after 10 s = ?

$$\text{Acceleration (1)} = \frac{\vec{F}}{m}$$

$$\Rightarrow a = \frac{(20\hat{i} + 10\hat{j})}{2} \text{ N/kg}$$

$$\Rightarrow a = (10\hat{i} + 5\hat{j}) \text{ N/kg}$$

Displacement along x -axis,

$$x = \left(u_x t + \frac{1}{2} a_x t^2 \right) \hat{i}$$

$$\Rightarrow x = \left(0 + \frac{1}{2} \times 10 \times 10^2 \right) \hat{i}$$

$$\Rightarrow x = 500\hat{i} \text{ m}$$

Displacement along y -axis

$$y = \left(u_y t + \frac{1}{2} a_y t^2 \right) \hat{j}$$

$$= \left(0 + \frac{1}{2} \times 5 \times 10 \times 10 \right) \hat{j} = 250 \hat{j} \text{ m}$$

Hence, displacement along x -axis = 500 m

19. Consider a frame that is made up of two thin massless rods AB and AC as shown in the figure. A vertical force \vec{P} of magnitude 100 N is applied at point A of the frame.

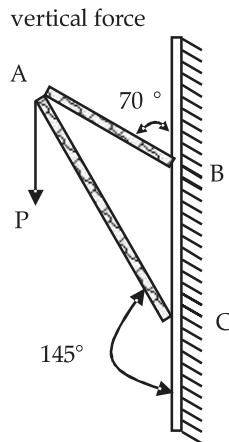

Suppose the force is \vec{P} resolved parallel to the arms AB and AC of the frame.

The magnitude of the resolved component along the arm AC is x N.

The value of x , to the nearest integer, is _____.

[Given: $\sin(35^\circ) = 0.573$, $\cos(35^\circ) = 0.819$
 $\sin(110^\circ) = 0.939$, $\cos(110^\circ) = -0.342$]

[JEE (Main) – 16th March 2021 - Shift-1]

Sol. Correct answer is [82]

Component of P along AC is $P \cos 35^\circ$

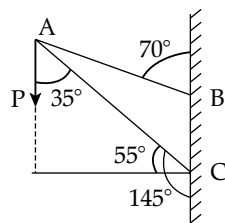

Given: $P = 100 \text{ N}$ and $\cos 35^\circ = 0.819$

The magnitude of force along the arm AC

$$F_{AC} = P \cos 35^\circ$$

$$= 100 \times 0.819 \text{ N} = 81.9 \text{ N}$$

$$\approx 82 \text{ N}$$

20. A boy of mass 4 kg is standing on a piece of wood having mass 5 kg. If the coefficient of friction between the wood and the floor is 0.5,

the maximum force that the boy can exert on the rope so that the piece of wood does not move from its place is _____ N.

(Round off to the Nearest Integer)

[Take $g = 10 \text{ ms}^{-2}$]

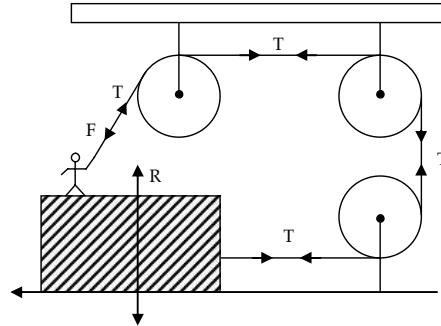

[JEE (Main) – 17th March 2021 - Shift-2]

Sol. Correct answer is [30]

Mass of a boy = 4 kg

Mass of a wood = 5 kg

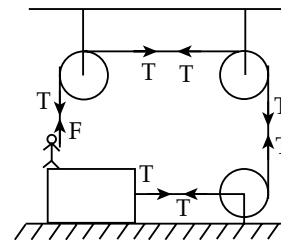

$$\mu = 0.5$$

$$T + N_1 = 90$$

$$N_1 = (90 - T)$$

$$f \text{ (friction)} = T$$

$$\mu (90 - T) = T$$

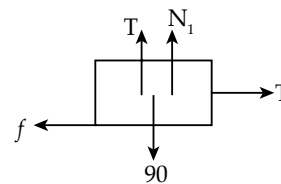

$$90 - T = 2T$$

$$3T = 90$$

$$T = 30 \text{ N}$$

21. A bullet of mass 0.1 kg is fired on a wooden block to pierce through it, but it stops after moving a distance of 50 cm into it. If the velocity of bullet before hitting the wood is 10 m/s and it slows down with uniform deceleration, then the magnitude of effective retarding force on the bullet is ' x ' N.

The value of ' x ' to the nearest integer is

[JEE (Main) – 18th March 2021 - Shift-1]

Sol. Correct answer is [10]

Given, Mass of bullet = 0.1 kg
Velocity of a bullet = 10 m/s

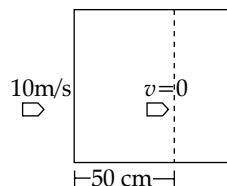

Using 3rd equation of motion

$$v^2 = u^2 - 2as$$

$$0 = 100 - 2a \times \frac{50}{100}$$

$$a = 100 \text{ m/s}^2$$

Retarding force (F) = 0.1 × 100
⇒ 10 N

22. A bullet of 10 g, moving with velocity v , collides head-on with the stationary bob of a pendulum and recoils with velocity 100 m/s. The length of the pendulum is 0.5 m and mass of the bob is 1 kg. The minimum value of $v = \underline{\hspace{2cm}}$ m/s so, that the pendulum describes a circle.

(Assume the string to be inextensible and $g = 10 \text{ m/s}^2$)

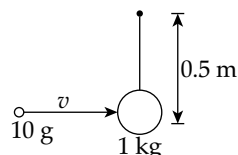

[JEE (Main) – 27th Aug. 2021 - Shift-2]

Sol. Correct answer is [400]

When bullet strikes with velocity v with bob of 1 kg.

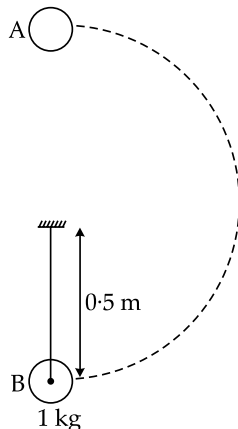

The momentum by bullet is imparted to bob and it goes high, and just manages to reach highest point, if so it will complete the circle.

So, the velocity that Bob should gain = $\sqrt{5gR}$

$$= \sqrt{5 \times 10 \times 0.5} = \sqrt{50 \times 0.5}$$

$$= 5 \text{ m/s}$$

Now applying momentum conservation

$$m_{\text{bullet}} \times v_{\text{min}} = -m_{\text{bullet}} \times v_{\text{Recoil}} + m_{\text{bob}} \times \sqrt{5gR}$$

$$\frac{10}{100} \times v_{\text{min}} = \frac{-10}{1000} \times 100 + 0.5 \times 5$$

$$v_{\text{min}} = 400 \text{ m/s.}$$

23. The coefficient of static friction between a wooden block of mass 0.5 kg and a vertical rough wall is 0.2. The magnitude of horizontal force that should be applied on the block to keep it adhered to the wall will be $\underline{\hspace{2cm}}$ N. [$g = 10 \text{ ms}^{-2}$] [JEE (Main) – 24th Feb. 2021 - Shift-1]

Sol. Correct answer is [25]

Applying force balance equation in vertical and horizontal direction.

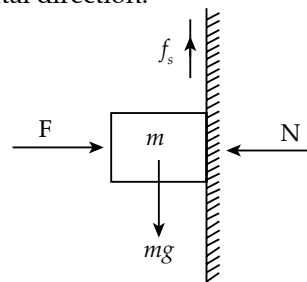

Force balance in vertical direction

$$f_s = mg \quad \dots(i)$$

$$F = N \quad \dots(ii)$$

From equation (i) and (ii)

$$f_s = \mu N = mg$$

$$N = \frac{mg}{\mu} = \frac{0.5 \times 10}{0.2}$$

$$F = N = 25 \text{ N}$$

Hence, the magnitude of horizontal force be 25 N

24. An inclined plane is bent in such a way that the vertical cross-section is given by $y = \frac{x^2}{4}$ where y is in vertical and x in horizontal direction. If the upper surface of this curved plane is rough with coefficient of friction $\mu = 0.5$, the maximum height in cm at which a stationary block will not slip downward is $\underline{\hspace{2cm}}$ cm.

[JEE (Main) – 24th Feb. 2021 - Shift-1]

Sol. Correct answer is [25]

Given, equation of vertical cross-section

$$y = \frac{x^2}{4}$$

Coefficient of friction (μ) = 0.5

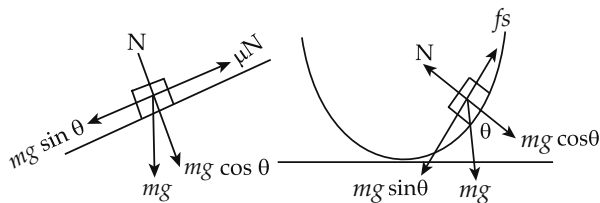

Now, applying the force balance equation,

$$\begin{aligned} mg \sin \theta &= \mu N = f_s \\ \Rightarrow mg \sin \theta &= \mu mg \cos \theta \\ \Rightarrow \tan \theta &= \mu \end{aligned} \quad \dots(i)$$

Now,

$$y = \frac{x^2}{4}$$

$$\tan \theta = \frac{dy}{dx} = \frac{2x}{4} = \frac{x}{2}$$

From equation (i)

$$\begin{aligned} \Rightarrow \tan \theta &= \mu = \frac{x}{2} \\ \Rightarrow x &= 2\mu = 2 \times 0.5 \\ \Rightarrow x &= 1 \end{aligned}$$

Hence,

$$y = \frac{x^2}{4} = \frac{1}{4}$$

$$y = 0.25 \text{ m}$$

or $y = 25 \text{ cm}$

25. As shown in the figure, a block of mass $\sqrt{3} \text{ kg}$ is kept on a horizontal rough surface of coefficient of friction $\frac{1}{3\sqrt{3}}$. The critical force to be applied on the vertical surface as shown at an angle 60° with horizontal such that it does not move, will be $3x$. The value of x will be _____.

$$\left[g = 10 \text{ m/s}; \sin 60^\circ = \frac{\sqrt{3}}{2}; \cos 60^\circ = \frac{1}{2} \right]$$

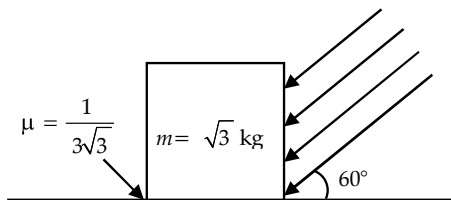

[JEE (Main) – 26th Feb. 2021 - Shift-1]

Sol. Correct answer is [10]

Given,

Mass of the block (m) = $\sqrt{3} \text{ kg}$

Coefficient of friction (μ) = $\frac{1}{3\sqrt{3}}$

Angle (θ) = 60°

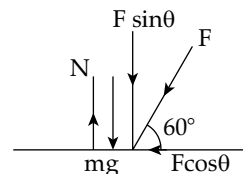
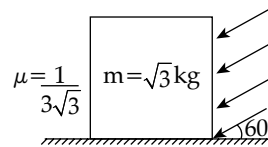

From, Free body diagram

$$N = F \sin \theta + mg$$

For critical condition,

$$F \cos \theta = \mu N$$

$$\Rightarrow F \cos 60^\circ = \frac{1}{3\sqrt{3}} (F \sin 60^\circ + \sqrt{3} \times 10)$$

$$\Rightarrow \frac{F}{2} = \frac{F}{3\sqrt{3}} \times \frac{\sqrt{3}}{2} + \frac{\sqrt{3}}{3\sqrt{3}} \times 10$$

$$\Rightarrow \frac{F}{2} = \frac{F}{6} + \frac{10}{3} \Rightarrow \frac{3F - F}{6} = \frac{10}{3}$$

$$\Rightarrow F = 10 \text{ N}$$

26. A person standing on a spring balance inside a stationary lift measures 60 kg . The weight of that person if the lift descends with uniform downward acceleration of 1.8 m/s^2 will be _____ N. [$g = 10 \text{ m/s}^2$]

[JEE (Main) – 26th Feb. 2021 - Shift-1]

Sol. Correct answer is [492]

Given,

Mass of the man in stationary lift

$$m = 60 \text{ kg}$$

Downward acceleration (a) = 1.8 m/s^2

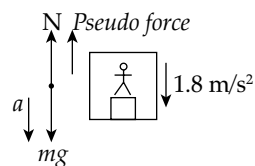

$$Mg - N = Ma \Rightarrow N = Mg - Ma$$

$$\Rightarrow N = (60 \times 10 - 60 \times 1.8) \text{ N}$$

$$\Rightarrow N = 492 \text{ N}$$

27. A body of mass 2 kg moves under a force of $2\hat{i} + 3\hat{j} + 5\hat{k} \text{ N}$. It starts from rest and was at the origin initially. After 4 s , its new coordinates are $(8, b, 20)$. The value of b is _____.
- (Round off to the nearest integer)

[JEE (Main) – 16th March 2021 - Shift-2]

Sol. Correct answer is [12]

Given, Mass = 2 kg $F = (2\hat{i} + 3\hat{j} + 5\hat{k})$ N

Time = 4 seconds

Using 2nd equation of motion

$$S = ut + \frac{1}{2} at^2$$

$$S = [\vec{r}_2 - \vec{r}_1] = [x\hat{i} + y\hat{j} + z\hat{k} - o\hat{i} - o\hat{j} - o\hat{k}]$$

$$S = x\hat{i} + y\hat{j} + z\hat{k}$$

$$x\hat{i} + y\hat{j} + z\hat{k} = \frac{1}{2} \left[\frac{2\hat{i} + 3\hat{j} + 5\hat{k}}{2} \right] [4]^2$$

$$8\hat{i} + b\hat{j} + 20\hat{k} = 8\hat{i} + 12\hat{j} + 20\hat{k}$$

$$b = 12$$

28. Two blocks ($m = 0.5$ kg and $M = 4.5$ kg) are arranged on a horizontal frictionless table as shown in figure. The coefficient of static friction between the two blocks is $3/7$. Then the maximum horizontal force that can be applied on the larger block so that the blocks move together is N. (Round off to the nearest integer) [Take g as 9.8 ms^{-2}]

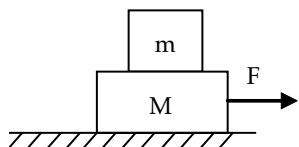

[JEE (Main) – 17th March 2021 - Shift-1]

Sol. Correct answer is [21]

Friction (f) = μmg

$$= \frac{3}{7} \times \frac{5}{10} \times 9.8 = 2.1 \text{ N}$$

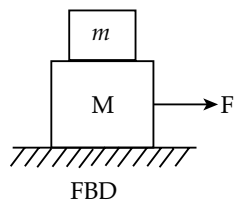

$$F = f + Ma$$

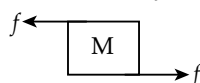
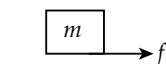

$$\begin{aligned} \Rightarrow F &= 2.1 + 4.5 [\mu g] \\ &= 2.1 + 4.5 \left[\frac{3}{7} \times 9.8 \right] \\ &= 21 \text{ N} \end{aligned}$$

29. A body of mass 1 kg rests on a horizontal floor with which it has a coefficient of static friction $\frac{1}{\sqrt{3}}$. It is desired to make the body move by applying the minimum possible force F N. The value of F will be _____. (Round off to the nearest integer) [Take $g = 10 \text{ ms}^{-2}$]

[JEE (Main) – 17th March 2021 - Shift-2]

Sol. Correct answer is [5]

Minimum possible force 'F'

$$F = \frac{\mu mg}{\sqrt{1 + \mu^2}} = \frac{\frac{1}{\sqrt{3}} \times 1 \times 10}{\sqrt{1 + \frac{1}{3}}} = 5 \text{ N}$$

30. A uniform chain of length 3 metre and mass 3 kg overhangs a smooth table with 2 metre laying on the table. If k is the kinetic energy of the chain in joule as it completely slips off the table, then value of k is _____. (Take $g = 10 \text{ m/s}^2$)

[JEE (Main) – 26th Aug. 2021 - Shift-1]

Sol. Correct answer is [40]

When the chain falls its center of mass goes down from $x_1 = \frac{1}{2}$ m to $x_2 = \frac{3}{2}$ m.

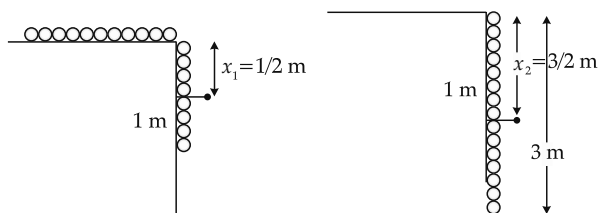

From conservation of mechanical energy

$$\begin{aligned} \Delta k &= U_f - U_i \\ &= \left(3 \times g \times \frac{3}{2} \right) - \left(1 \times g \times \frac{1}{2} \right) \\ &= 45 - 5 = 40 \text{ J} \end{aligned}$$

31. The coefficient of static friction between two blocks is 0.5 and the table is smooth. The maximum horizontal force that can be applied to move the blocks together is _____. N. (take $g = 10 \text{ ms}^{-2}$)

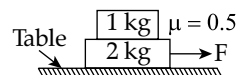

[JEE (Main) – 26th Aug. 2021 - Shift-2]

Sol. Correct answer is [15]

If both the block move together, then

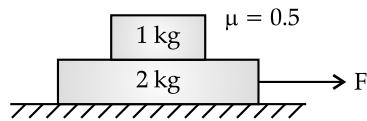

$$F = (m_1 + m_2)a$$

$$\Rightarrow a = \frac{f}{m_1 + m_2}$$

where a is acceleration of combined system.

$$a = \frac{f}{3}$$

When the system will move with $\frac{F}{3}$ acceleration

the 1 kg block will experience a pseudo force

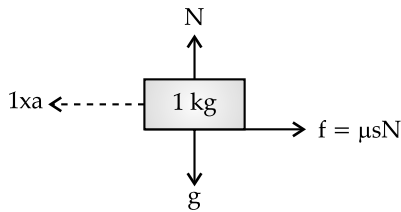

The F.B.D. suggests in limiting condition

Friction force $f =$ Pseudo force $(1 \times a)$

$$\mu_s \times mg = 1 \times a = 1 \times \frac{F}{3}$$

$$F_{\max} = 3 \mu_s \times mg = 3 \times 0.5 \times 1 \times 10$$

$$F_{\max} = 15 \text{ N}$$

32. A block starts moving up an inclined plane of inclination 30° with an initial velocity of v_0 . It comes back to its initial position with velocity $\frac{v_0}{2}$. The value of the coefficient of kinetic friction between the block and the inclined plane is close to $\frac{I}{1000}$. The nearest integer to I is:

[JEE (Main) – 3rd Sep. 2020 - Shift-2]

Sol. Correct answer is [346]

Given: Angle of inclination of the plane is 30° , the initial velocity of the block up the plane is v_0 , initial velocity of the block down the plane is $\frac{v_0}{2}$, coefficient of kinetic friction between the block and the plane is $\frac{I}{1000}$.

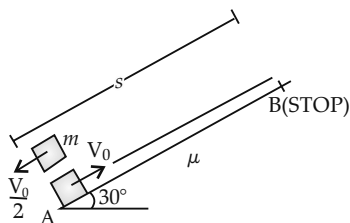

Upward retardation of the block:

$$a_1 = g \sin 30^\circ + \mu g \cos 30^\circ$$

$$a_1 = \frac{g}{2} + \frac{\sqrt{3}}{2} \mu g \quad \dots(i)$$

Final velocity of the block when it reaches the top, at point B is zero:

$$0 = v_0^2 - 2a_1s$$

$$s = \frac{v_0^2}{2a_1} \quad \dots(ii)$$

Downward acceleration of the block:

$$a_2 = g \sin 30^\circ - \mu g \cos 30^\circ$$

$$a_2 = \frac{g}{2} - \frac{\sqrt{3}}{2} \mu g \quad \dots(iii)$$

Initial velocity of the block when it returns from the top, at point B:

$$\left(\frac{v_0}{2}\right)^2 = 0 + 2a_2s \Rightarrow s = \frac{v_0^2}{8a_2} \quad \dots(iv)$$

Equating (ii) and (iv):

$$\frac{v_0^2}{2a_1} = \frac{v_0^2}{8a_2}$$

$$a_1 = 4a_2 \quad \dots(v)$$

That gives, $\frac{g}{2} + \frac{\sqrt{3}}{2} \mu g = 4 \times \left(\frac{g}{2} - \frac{\sqrt{3}}{2} \mu g\right)$

$$1 + \sqrt{3}\mu = 4 - 4\sqrt{3}\mu$$

$$5\sqrt{3}\mu = 3$$

$$\mu = \frac{\sqrt{3}}{5}$$

$$\mu = 0.346$$

$$\mu = \frac{346}{1000}$$

$$I = 346$$

33. A small block of mass of 0.1 kg lies on a fixed inclined plane PQ which makes an angle θ with the horizontal. A horizontal force of 1 N acts on the block through its centre of mass as shown in the figure.

Discuss the values of θ for which the block remains stationary, with and without frictional forces. [Take $g = 10 \text{ m/s}^2$.]

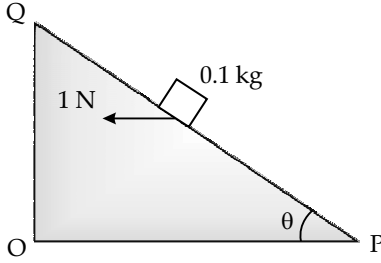

Sol. Correct answer is [45]

Given : Mass of block, $m = 0.1 \text{ kg}$,
 Magnitude of horizontal force acting on the block, $F = 1 \text{ N}$,
 Acceleration due to gravity, $g = 10 \text{ m/s}^2$.

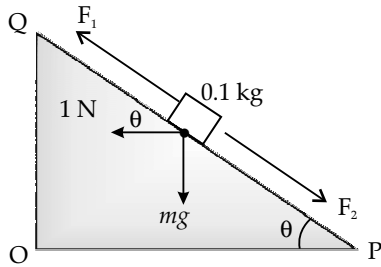

The forces acting on the block along the incline:
 $F_2 = mg \sin \theta = 0.1 \times 10 \times \sin \theta = \sin \theta$.
 $F_1 = 1 \cos \theta = \cos \theta$.

For the block to be stationary:
 $F_2 = F_1$;
 $\sin \theta = \cos \theta$;
 $\theta = 45^\circ$

That is the block remains stationary on its own without the help of frictional force for $\theta = 45^\circ$.
 For $\theta > 45^\circ$; $\sin \theta > \cos \theta$; $F_2 > F_1$.
 So, the block is stationary for $\theta > 45^\circ$ and frictional force acting towards Q.
 Similarly, the block is stationary for $\theta < 45^\circ$ and frictional force acting towards P.

34. A block is moving on an inclined plane making an angle 45° with the horizontal and the coefficient of friction is μ . The force required to just push it up the inclined plane is 3 times the force required to just prevent it from sliding down. What should be the value of N if $N = 10\mu$?

Sol. Correct answer is [5]

Given: Angle of inclination of plane,
 $\theta = 45^\circ$,
 Coefficient of friction between the block and the incline $= \mu$,
 Force required to push the block up the incline $= F_1$,
 Force required to just prevent the block from sliding down $= F_2$ and $F_1 = 3F_2$,
 The normal force $N = 10\mu$.
To find: Value of N .

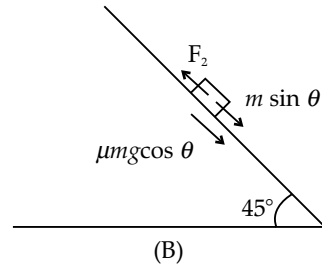
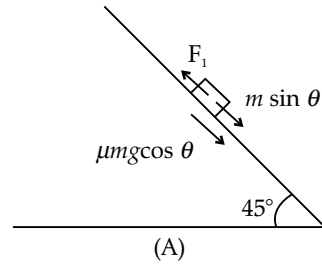

From diagram (A):

$$F_1 = mg \sin \theta + \mu mg \cos \theta \quad \dots(i)$$

From diagram (B):

$$F_2 = mg \sin \theta - \mu mg \cos \theta \quad \dots(ii)$$

Given: $F_1 = 3F_2$;

$$mg \sin \theta + \mu mg \cos \theta = 3(mg \sin \theta - \mu mg \cos \theta);$$

$$4 \mu mg \cos \theta = 2mg \sin \theta;$$

$$4\mu \cos 45^\circ = 2 \sin 45^\circ;$$

$$\mu = \frac{2}{4} = \frac{1}{2}.$$

$$N = 10 \mu = 10 \times \frac{1}{2} = 5$$

35. Find the acceleration of mass m in both cases. The pulley arrangement for both figure a and b is identical and the mass of the rope is negligible.

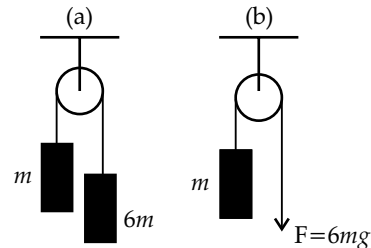

Sol. Correct answer is [5]

Given: In figure (1) mass m is lifted by attaching another mass $6m$ at the other end of the rope, In figure (2) mass m is lifted by applying a downward force of $6mg$ at the other end of the rope.

To find: The acceleration of mass m in both the cases.

Case a: Total force acting on mass m ,

$$F_a = 6mg - mg = 5mg;$$

Total mass to be pulled by this force:

$$m_a = 6m + m = 7m$$

Acceleration of mass m :

$$a = \frac{F_a}{m_a} = \frac{5mg}{7m} = \frac{5}{7}g.$$

Case b : Total force acting on mass m ,

$$F_b = 6mg - mg = 5mg;$$

Total mass to be pulled by this force:

$$m_b = m.$$

Acceleration of mass m :

$$a = \frac{F_b}{m_b} = \frac{5mg}{m} = 5g.$$

36. Find the angle θ for the system of pulleys shown in the diagram below, where $M = \sqrt{3}m$. Neglect the mass of pulleys and strings and assume they are frictionless.

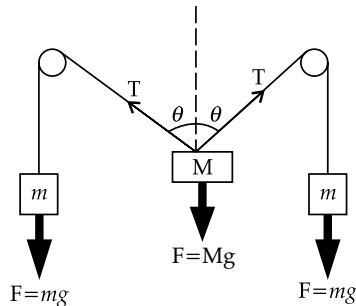

Sol. Correct answer is [30]

Given: $M = \sqrt{3}m$... (i)

the pulleys and strings are massless and frictionless.

To find: Angle θ .

For the system to be in equilibrium :

$$T = mg \quad \dots (ii)$$

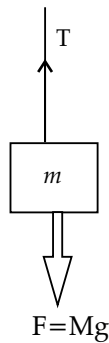

Balancing the forces acting on mass M :

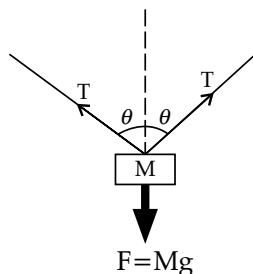

$$T \cos \theta + T \cos \theta = Mg$$

(Put value of M from equation (i) and value of T from equation (ii))

$$2mg \cos \theta = \sqrt{3}mg;$$

$$\cos \theta = \frac{\sqrt{3}}{2};$$

$$\theta = 30^\circ.$$

37. Find the acceleration of mass m in both cases. The pulley arrangement for both figure a and b is identical and the mass of the rope is negligible.

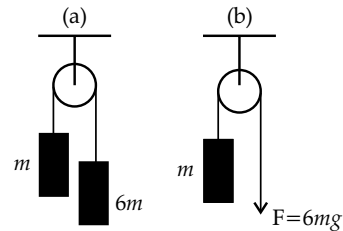

Sol. Correct answer is [5]

Given : In figure (1) mass m is lifted by attaching another mass $6m$ at the other end of the rope,

In figure (2) mass m is lifted by applying a downward force of $6mg$ at the other end of the rope.

To find : The acceleration of mass m in both the cases.

Case a : Total force acting on mass m ,

$$F_a = 6mg - mg = 5mg;$$

Total mass to be pulled by this force :

$$m_a = 6m + m = 7m$$

Acceleration of mass m :

$$a = \frac{F_a}{m_a} = \frac{5mg}{7m} = \frac{5}{7}g.$$

Case b : Total force acting on mass m ,

$$F_b = 6mg - mg = 5mg;$$

Total mass to be pulled by this force :

$$m_b = m.$$

Acceleration of mass m :

$$a = \frac{F_b}{m_b} = \frac{5mg}{m} = 5g.$$