

# CURRENT ELECTRICITY

## Some Definitions

### ELECTRIC CURRENT

The rate of flow of electric charge across any cross-section is called electric current.

(a) Instantaneous electric current  $I = \frac{dq}{dt}$

(b) Average electric current  $I_{av} = \frac{\Delta q}{\Delta t}$

### Current Density

Current flowing per unit area through any cross-section is called current density.

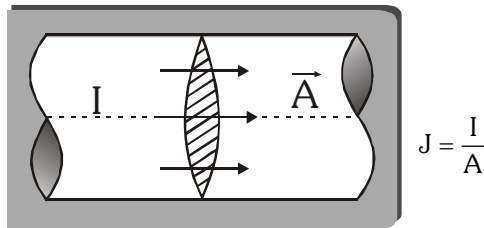

$$I = \vec{J} \cdot \vec{A} = JA \cos \theta$$

### Drift Velocity

Average velocity with which electrons drift from low potential end to high potential end of the conductor ( $v_d$ ). Drift velocity is given by

$$\vec{v}_d = -\frac{e\tau}{m} \vec{E} \quad (\text{in terms of applied electric field})$$

$$v_d = \frac{I}{neA} \quad (\text{in terms of current through the conductor})$$

From second relation

$I = neAv_d$  where  $A$  is the area of cross-section and " $Av_d$ " represents the rate of flow.

The term  $\frac{v_d}{E}$  is called mobility of charge

carriers, represented by  $\mu = \frac{v_d}{E} = \frac{e\tau}{m}$ .

(here  $\tau \rightarrow$  mean relaxation time depends on temperature  $\tau \propto \frac{1}{\sqrt{T}}$ ,  $T \rightarrow$  absolute temperature

of the conductor)

## OHM'S LAW

$$I = \frac{V}{R} \quad \text{where } R = \frac{l}{\sigma A} = \frac{\rho l}{A} \quad \text{where } \rho \text{ (resistivity)} = \frac{1}{\sigma}$$

Hence according to Ohm's law when  $R$  is constant  $I \propto V \Rightarrow I \sim V$  curve is a straight line (at constant temperature)

- Resistance of a conductor is given by

$$R = \frac{\rho l}{A} = \frac{ml}{ne^2\tau A}$$

where  $\rho$  is resistivity. Its units is  $\Omega \text{ m}$ .

- Resistivity of a conductor,  $\rho = \frac{m}{ne^2\tau}$  (where  $m$  is mass of electron,  $n$  is number density of free electrons,  $\tau$  is average relaxation time).

### Variatio in resistance (R)

**Variation with length:**  $R = \rho \frac{l}{A}$

- (a) If a wire is cut to alter its length, then area remains same.  $\therefore R \propto l$
- (b) If a wire is stretched or drawn out or folded, area varies but volume remains constant.  $\Rightarrow R \propto l^2$

For small percentage changes ( $< 5\%$ ) in length by stretching or folding, then,  $\frac{\Delta R}{R} = \frac{2\Delta l}{l}$

### Variation with area of cross-section or thickness

- (a) If area is increased / decreased but length is kept same.

$$\therefore R \propto \frac{1}{A} \quad \text{or} \quad R \propto \frac{1}{r^2} \quad (r = \text{radius / thickness})$$

- (b) If area is increased/decreased but volume remains same.

$$R \propto \frac{1}{A^2} \quad \text{or} \quad R \propto \frac{1}{r^4}$$

### For Conductors :

$\rho_t = \rho_0(1+\alpha t)$ , where ' $\alpha$ ' is temperature.

Coefficient of resistivity.

$$\text{As } R \propto \rho \Rightarrow R = R_0(1 + \alpha t)$$

( $R_0$  is the resistance at reference temperature)

$$\text{At temperature } t_1, R_1 = R_0(1 + \alpha t_1)$$

$$\text{At temperature } t_2, R_2 = R_0(1 + \alpha t_2)$$

$$\Rightarrow \alpha = \frac{R_2 - R_1}{R_0(t_2 - t_1)}, R_0 = \frac{R_2 - R_1}{\alpha(t_2 - t_1)}$$

**COMBINATION OF RESISTANCES**

**Resistance In Series (Same Current)**

$R = R_1 + R_2 + R_3 + \dots + R_n$  and  
 $V = V_1 + V_2 + V_3 + \dots + V_n$ .

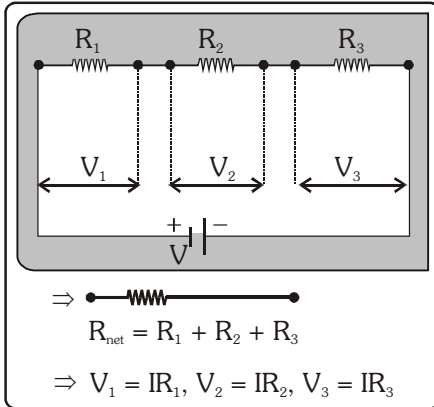

**Resistance In Parallel (Same Potential difference)**

Effective resistance (R) then

$\frac{1}{R} = \frac{1}{R_1} + \frac{1}{R_2} + \frac{1}{R_3} + \dots + \frac{1}{R_n}$

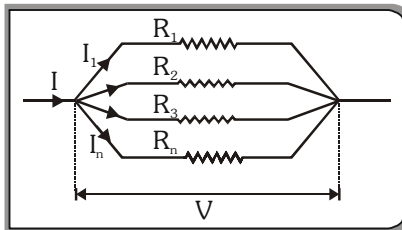

For two resistance  $R = \frac{R_1 R_2}{R_1 + R_2}$

**Equivalent Resistance In Cube (Symmetry)**

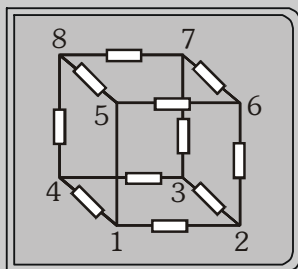

(a) Resistance between two nearer corners

$R_{12} = \frac{7}{12}r \quad C_{12} = \frac{12C}{7}$

(b) Resistance across face diagonal

$R_{13} = \frac{3}{4}r \quad C_{13} = \frac{4C}{3}$

(c) Resistance across main diagonal

$R_{17} = \frac{5}{6}r \quad C_{17} = \frac{6C}{5}$

**KIRCHHOFF'S LAWS**

**1. Junction Rule (K.C.L.)**

It is based on conservation of charge.

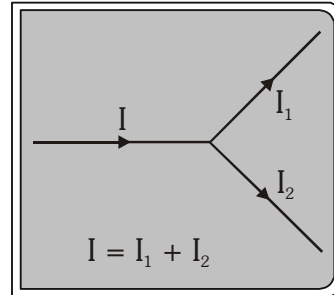

**2. Loop Rule (K.V.L.)**

For any closed loop, total rise in potential + total fall in potential = 0.

It is based on conservation of energy.

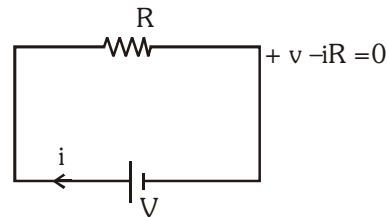

Terminal Voltage  $V = E - iR$  discharging,  
 $E + iR$  charging

**Cell**

- **EMF (E)** : The potential difference across the terminals of a practical cell when no current is being drawn from it.
- **Internal Resistance (r)** : The opposition of flow of current inside the cell. It depends on
  - (i) Distance between electrodes :  $\uparrow r \uparrow$
  - (ii) Area of electrodes :  $\uparrow r \downarrow$
  - (iii) Concentration of electrolyte :  $\uparrow r \uparrow$
  - (iv) Temperature :  $\uparrow r \downarrow$

**Series Combination of Cells :**

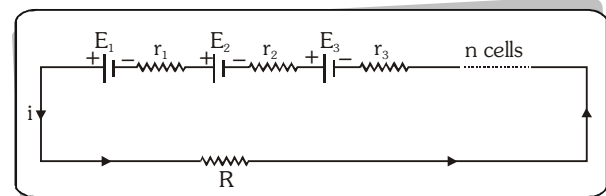

(a)  $E_{equivalent} = E_1 + E_2 + E_3 + \dots + E_n$

(b)  $r_{equivalent} = r_1 + r_2 + r_3 + \dots + r_n$

(c) Current  $i = \frac{\sum E_i}{\sum r_i + R}$

(d) If all cells have equal emf E and equal internal resistance r then  $i = \frac{nE}{nr + R}$

**Cases :**

(i) If  $nr \gg R \Rightarrow i = \frac{E}{r}$

(ii) If  $nr \ll R \Rightarrow i = \frac{nE}{R}$

**Parallel Combination of cells :**

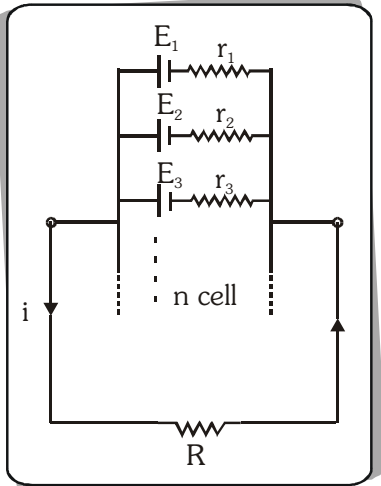

(a) 
$$E_{\text{equivalent}} = \frac{\frac{E_1}{r_1} + \frac{E_2}{r_2} + \frac{E_3}{r_3} + \dots}{\frac{1}{r_1} + \frac{1}{r_2} + \frac{1}{r_3} + \dots}$$

(b) 
$$r_{\text{equivalent}} = \frac{1}{\frac{1}{r_1} + \frac{1}{r_2} + \frac{1}{r_3} + \dots}$$

(c) If all cells have equal emf.  $E$  and internal resistance  $r$  then  $E_{\text{equivalent}} = E$

$$r_{\text{equivalent}} = \frac{r}{n} \Rightarrow \text{current } i = \frac{E}{\frac{r}{n} + R}$$

**Mixed combination**

Total number of identical cell in this circuit is  $nm$ . If  $n$  cells connected in a series and there are  $m$  such branches in the circuit than the internal resistance of the cells connected in a row =  $nr$

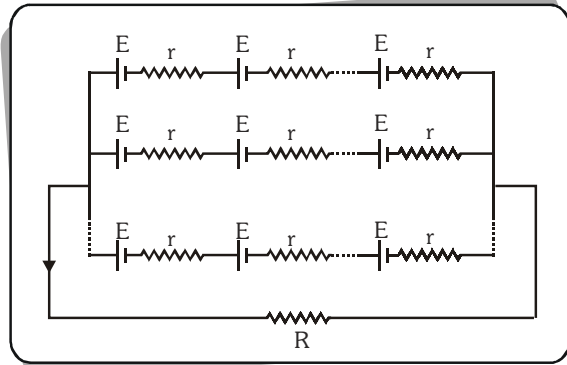

Total internal resistance of the circuit  $\frac{1}{r_{\text{net}}} = \frac{1}{nr} + \frac{1}{nr} + \dots$  upto  $m$  turns

( $\because$  There are such  $m$  rows)  $r_{\text{net}} = \frac{nr}{m}$

Total e.m.f. of the circuit = total e.m.f. of the cells connected in a row  $E_T = nE$

$$I = \frac{E_{\text{net}}}{R + r_{\text{net}}} = \frac{nE}{R + \frac{nr}{m}}$$

Current in the circuit is maximum when external resistance in the circuit is equal to the total internal resistance of the

cells  $R = \frac{nr}{m}$

**WHEAT STONE BRIDGE**

When current through the galvanometer is zero (null point or zero deflection)  $\frac{P}{Q} = \frac{R}{S}$ .

When  $PS > QR, V_c < V_d$  &  $PS < QR, V_c > V_d$  or  $PS = QR \Rightarrow$  products of opposite arms are equal.

Potential difference between  $C$  &  $D$  at null point is zero . The null point is not affected by resistance of  $G$  &  $E$ . It is not affected even if the positions of  $G$  &  $E$  are interchanged.

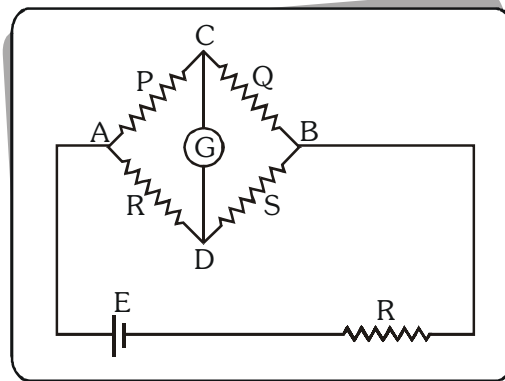



**Galvanometer :**

An instrument used to measure strength of current by measuring the deflection of the coil due to torque produced by a magnetic field.

$$T \propto i \propto \theta$$

A galvanometer can be converted into ammeter & voltmeter of varied scale as below.

**Ammeter :**

It is a modified form of suspended coil galvanometer, it is used to measure current. A shunt (small resistance) is connected in parallel with galvanometer to convert into ammeter.

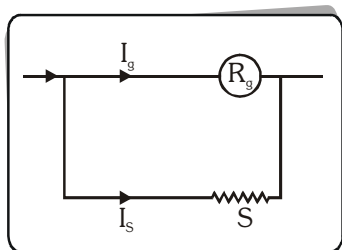

$$S = \frac{I_g R_g}{I - I_g}$$

where

$R_g$  = galvanometer resistance

$I_g$  = Maximum current that can flow through the galvanometer.

$I$  = Maximum current that can be measured using the given ammeter.

An ideal ammeter has zero resistance.

**Voltmeter :**

A high resistance is put in series with galvanometer. It is used to measure potential difference.

$$I_g = \frac{V_0}{R_g + R}; R \rightarrow \infty, \text{ Ideal voltmeter}$$

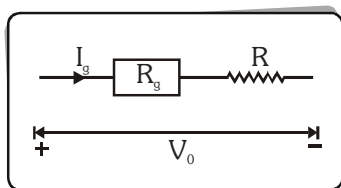
**Electrical Power :**

The energy liberated per second in a device is called its power. The electrical power  $P$  delivered by an electrical device is given by  $P = VI$ , where  $V$  = potential difference across device &  $I$  = current. If the current enters the higher potential point of the device then power is consumed by it (i.e. acts as load). If the current enters the lower potential point then the device supplies power (i.e. acts as source). Power consumed by a resistor

$$P = I^2 R = VI = \frac{V^2}{R}$$

**Heating Effect Of Electric Current :**

When a current is passed through a resistor energy is wasted in overcoming the resistances of the wire. This energy is converted into heat

$$W = VI t = I^2 R t = \frac{V^2}{R} t$$

**Joules Law Of Electrical Heating :**

The heat generated (in joules) when a current of  $I$  ampere flows through a resistance of  $R$  ohm for  $T$  second is given by :

$$H = I^2 R T \text{ joule} = \frac{I^2 R T}{4.2} \text{ calories.}$$

If current is variable passing through the conductor then we use for heat produced in resistance in time

$$0 \text{ to } T \text{ is: } H = \int_0^T I^2 R dt$$

**Unit Of Electrical Energy Consumption :**

1 unit of electrical energy

= kilowatt hour

= 1 kWh =  $3.6 \times 10^6$  joules.

♦ **Series combination of Bulbs**

$$\frac{1}{P_{\text{total}}} = \frac{1}{P_1} + \frac{1}{P_2} + \frac{1}{P_3} + \dots$$

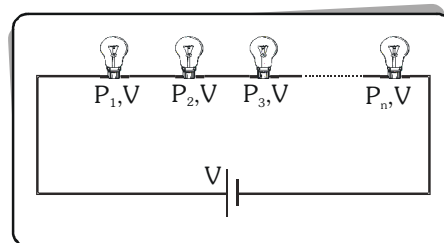
♦ **Parallel combination of Bulbs**

$$P_{\text{total}} = P_1 + P_2 + P_3 + \dots$$

